

OPERATING INSTRUCTIONS

MEDAP TAPPING UNIT FOR BRONCHIAL / SURGICAL ASPIRATION FINA VAC B 800

MEDAP 

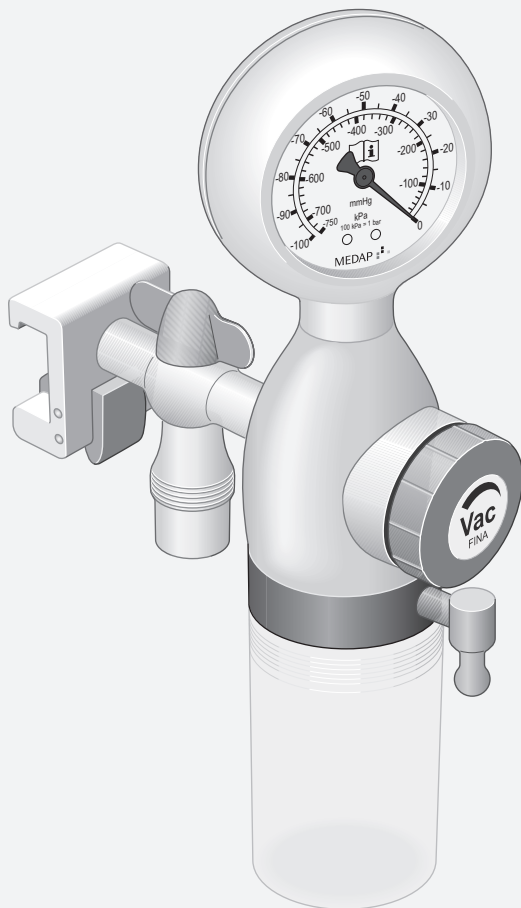

Subject to technical modification!

Illustrations and technical specifications may vary slightly from those in these operating instructions as a result of ongoing product development.

V28 2020-08





Table of contents

1	Introduction	5
1.1	Foreword	5
1.2	How to use these operating instructions	5
1.2.1	Abbreviations	5
1.2.2	Symbols	5
1.2.2.1	Cross-references	5
1.2.2.2	Actions and responses	5
1.2.3	Definitions	6
1.2.3.1	Design of safety notes	6
1.2.3.2	Structure of notes	6
1.3	Symbols used.....	6
1.4	Disposal.....	7
1.4.1	Packaging	7
1.4.2	ATMOS products.....	7
1.5	Overview	8
1.5.1	Overview of FINA VAC B 800.....	8
1.5.2	Overview of the FINA VAC B 800 versions	9
1.6	Basic requirements.....	9
1.6.1	Use in accordance with the intended purpose	9
1.6.2	Applicable standards.....	10
1.6.3	Intended purpose	10
1.6.4	Versions of the FINA VAC B 800.....	11
1.6.5	Interface description.....	12
1.6.5.1	Vacuum connection tube	12
1.6.5.2	Hydrophobic bacterial and viral filter	12
1.6.5.3	Septic fluid jar including septic fluid jar cap	12
1.6.5.4	Suction tube.....	13
1.6.5.5	Fingertip.....	13
1.6.5.6	Utensil.....	13
1.6.5.7	Mechanical overflow protection	13
2	Safety notes	14
2.1	General safety notes	14
2.2	Product safety notes.....	14
3	Initial operation.....	17
3.1	Equipment inspection	17
3.2	Mounting.....	17
3.2.1	Mounting the vacuum gauge.....	17
3.2.2	Connection to the terminal unit	18
3.2.2.1	General.....	18



- 3.2.2.2 Version A..... 18
- 3.2.2.3 Version B 19
- 3.2.2.4 Version C 19
- 3.2.2.5 Version D 20
- 3.2.3 Assembly of the septic fluid jar and accessories 20
- 4 Operation 23**
- 4.1 Function test..... 23
- 4.2 Working with the product..... 23
- 5 Taking the unit out of operation..... 25**
- 5.1 Completing the aspiration process 25
- 6 Cleaning and disinfection..... 26**
- 6.1 General..... 26
- 6.2 Cleaning 27
 - 6.2.1 General 27
 - 6.2.2 Cleaning procedure..... 27
- 6.3 Disinfection 27
 - 6.3.1 General 27
 - 6.3.2 Suitable disinfectants 28
 - 6.3.3 Disinfection procedure 28
 - 6.3.4 Disinfection procedures 28
- 6.4 Product-specific safety notes 29
- 7 Maintenance..... 30**
- 7.1 General..... 30
- 7.2 Periodic tests..... 30
- 7.3 Malfunctions and troubleshooting..... 30
- 7.4 Repairs 31
- 7.5 Service hotline..... 31
- 7.6 Spare parts..... 31
- 7.7 Sending in the device 31
- 8 Technical specifications 33**
- 8.1 General..... 33
- 8.2 Ambient conditions 33
- 8.3 Technical specifications..... 33
- 8.4 Dimensions..... 33
- 8.5 Weight 33
- 9 Approved accessories 34**
- 9.1 Standard scope of delivery 34
- 9.2 Accessories 34
- 9.3 Accessories for compact suction unit / basic vacuum equipment 34
- 9.4 Accessories for mobile suction unit / basic vacuum equipment 35
- 9.5 Consumables 35

1 Introduction

1.1 Foreword

Your facility has selected the leading-edge medical technology made by ATMOS. We sincerely appreciate the trust you have placed in us.

1.2 How to use these operating instructions

These operating instructions are provided to familiarise you with the features of this ATMOS product. They are subdivided into several chapters.

Please note:

- Please read these operating instructions carefully and completely before using the product for the first time.
- Always proceed in accordance with the information contained herein.
- Store these operating instructions in a location near the product.

1.2.1 Abbreviations

EN	European standard
EEC	European Economic Community
VDE	Verband der Elektrotechnik Elektronik Informationstechnik (Association for Electrical, Electronic & Information Technology)

1.2.2 Symbols

1.2.2.1 Cross-references

References to other pages in these operating instructions are identified with a double arrow symbol '»»'.

1.2.2.2 Actions and responses



The '☒' symbol identifies an action taken by the user, while the '✓' symbol identifies the reaction that this will induce in the system.

Example:

- ☒ Turn on the light switch.
 - ✓ Lamp lights up.

1.2.3 Definitions



1.2.3.1 Design of safety notes

Pictogram	Descriptor	Text
	DANGER! Indicates a direct and immediate risk to persons which may be fatal or result in most serious injury.	The text for the safety note describes the type of risk and how to avert it.
	WARNING! Indicates a potential risk to persons or property which may result in a health hazard or grave property damage.	
	CAUTION! Indicates a potential risk to property which may result in property damage.	

Tab. 1: Design of safety notes

1.2.3.2 Structure of notes





Notes not referring to personal injury or property damage are structured as follows:







Pictogram	Descriptor	Reference to
	NOTE	Supplementary assistance or further useful information without potential injury to persons or property damage is described in the text of the note.
	ENVIRONMENT	Information regarding proper disposal.

Tab. 2: Structure of notes

1.3 Symbols used

Symbols are attached to products, type plates and packaging.

Symbols	Identification
	Labelling for products which were developed and are marketed in compliance with the Medical Devices Directive 93/42/EEC. Class Is, Im, IIa, IIb and III products are also marked with the identifying number of the Notified Body.
	Labelling in compliance with the ISO 15223-1 standard. Symbol for 'Product number'.
	Labelling in compliance with the ISO 15223-1 standard. Symbol for 'Serial number'.
	Labelling in compliance with the ISO 15223-1 standard. Symbol for 'Follow operating instructions'.

Symbols	Identification
	Labelling in compliance with the ISO 15223-1 standard. Symbol for 'Name and address of the manufacturer as well as date of manufacture'.
	Packaging label. Symbol for 'Keep dry'.
	Packaging label. Symbol for 'Caution! Do not overturn'.
	Packaging label. Symbol for 'Top'.
	Labelling in compliance with the ISO 15223-1 standard. Symbol for 'Temperature limitations'.
	Labelling in compliance with the ISO 15223-1 standard. Symbol for 'Relative humidity'.
	Labelling in compliance with the ISO 15223-1 standard. Symbol for 'Atmospheric pressure'.

Tab. 3: Symbols

1.4 Disposal



WARNING!

Infection hazard!

The product or some of its components may be contaminated after use.

Clean and disinfect the product before disposal.

1.4.1 Packaging

The packaging is made of materials compatible with the environment. ATMOS will dispose of the packaging materials upon request.

1.4.2 ATMOS products

ATMOS will take back used products or those which are no longer in service.

Please contact your ATMOS representative for more detailed information.

1.5 Overview

1.5.1 Overview of FINA VAC B 800

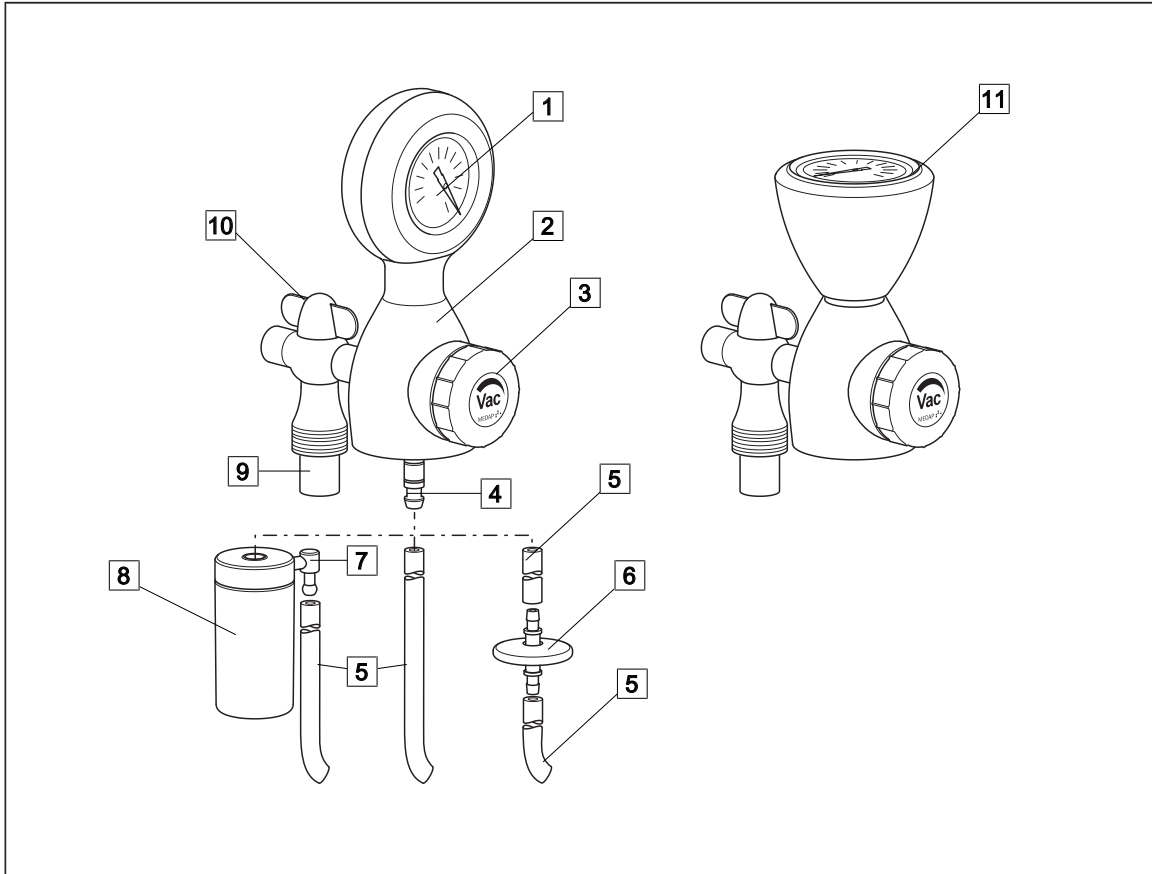

Fig. 1: Overview of FINA VAC B 800

- | | |
|--|--|
| 1 Vacuum gauge | 7 Tube connector of mechanical overflow protection |
| 2 Housing | 8 Mechanical overflow protection |
| 3 Control valve | 9 NIST connection |
| 4 Tube connector | 10 Shut-off valve |
| 5 Vacuum connection tube | 11 Top view vacuum gauge |
| 6 Hydrophobic bacterial and viral filter | |

1.5.2 Overview of the FINA VAC B 800 versions

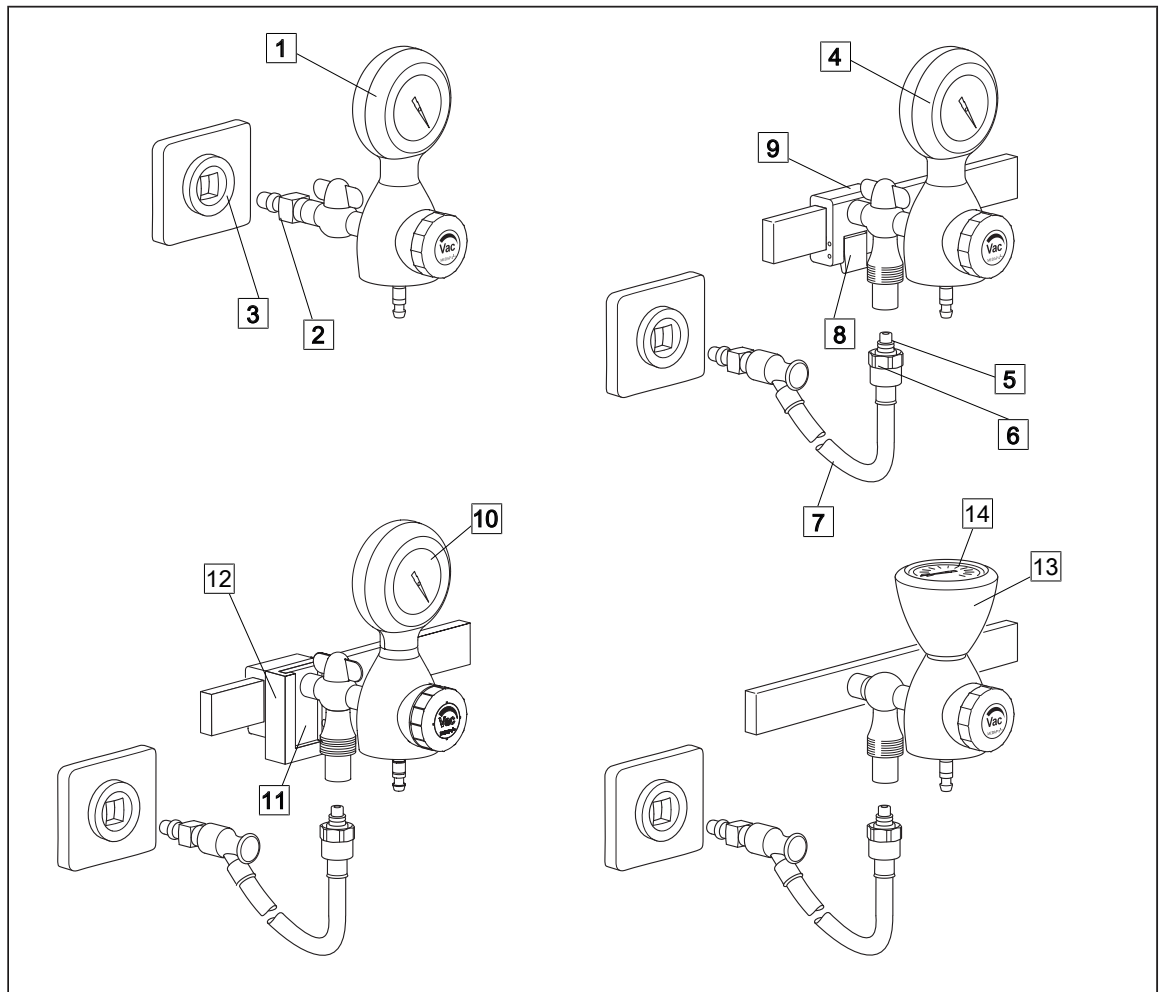

Fig. 2: Overview of the FINA VAC B 800 versions

1 **Version A**
Tapping unit with integrated gas pin

2 Plug

3 Terminal unit

4 **Version B**
Tapping unit with rail clamp and NIST connection

5 NIST nipple

6 NIST screw connection

7 Connection tube

8 Locking lever

9 Rail clamp

10 **Version C**
Tapping unit with equipment mount and NIST connection

11 Equipment mount

12 Equipment carrier

13 **Version D**
Tapping unit for screw connection, with NIST connection

14 Top view vacuum gauge

1.6 Basic requirements

1.6.1 Use in accordance with the intended purpose

Product

As per Annex IX to the Medical Devices Directive 93/42/EEC, this product belongs to class IIa.

In accordance with this directive, the product may only be used by persons who have been instructed how to use this product by an authorised person.

This product is to be used exclusively for human medicine.

When employed in commercial or business use, this product must be entered in the inventory.

Accessories

Accessories or combinations of accessories may be utilised only as and when indicated in these operating instructions.

Other accessories, combinations of accessories and consumable items may be used only if they have a valid certification, are intended expressly for the particular use and will not adversely affect performance, the prescribed ambient conditions or safety requirements.

1.6.2 Applicable standards

The product satisfies the basic requirements set forth in Annex I to Council Directive 93/42/EEC concerning medical devices (Medical Devices Directive) as well as the applicable national (German) codes and the Medical Devices Act (MPG) in Germany. This has also been demonstrated through the application of the corresponding standards which have been harmonised with Directive 93/42/EEC.

1.6.3 Intended purpose

Name:	FINA VAC B 800
Main function:	Aspiration of secretion, blood, serous fluids, vomit and rinsing fluids along with any contained particles
Medical indications / application:	For all applications which require aspiration, e.g. general surgeries (e.g. aspiration of wound cavities, abscesses), bronchial aspiration, during endoscopy for aspiration of secretion and in neurosurgery
Specification of the main function:	Drainage and temporary collection of body fluids. For the supply of vacuum, FINA VAC B 800 is connected to a terminal unit for vacuum of a central medical gas supply system with a pressure of -100 kPa to -60 kPa. A septic fluid jar, which has to be used, allows for temporary collection of drained body fluids.
User profile:	Doctor, medically trained staff
Patient groups:	Surgical aspiration: patients of all ages; Bronchial aspiration: primarily for adults; for paediatrics, FINA VAC P 350 would be an alternative.
Application organ:	Natural and artificial body orifices
Application time:	For continuous operation; in practice, short-term use on the patient (< 30 days)
Application site:	The application site is the clinical environment and doctor's practices which have a central vacuum source. The application of the product may only be performed by medically trained and instructed staff.

Contraindications:	<p>The FINA VAC B 800 may not be used for the following purposes:</p> <ul style="list-style-type: none"> • Outside the medical sector • In MR areas • In the home care sector • Being operated directly by the patient • For vacuum extraction • For the aspiration of flammable or explosive liquids • For the aspiration of smoke that is generated during HF and laser surgery without the connection of an intermediate smoke filter • With central gas supply systems with supply pressures other than -100 kPa to -60 kPa <p>Furthermore, the FINA VAC B 800 is not suitable for drainage and thoracic drainage. Usage in combination with disposable thoracic drainage systems with integrated vacuum regulation is excepted from this restriction.</p>
The product is:	Active
Sterility:	Not a sterile product
Single-use product / reprocessing:	The device and parts of the accessories are reusable. For information on reprocessing, cleaning and disinfection, please see the operating instructions.

1.6.4 Versions of the FINA VAC B 800

The connection of FINA VAC B 800 to the terminal unit depends on the model being used:

- **Version A:** Tapping unit with integrated gas pin. FINA VAC B 800 is fitted directly to the terminal unit.
- **Version B:** Tapping unit with rail clamp and NIST connection. FINA VAC B 800 is designed for mounting onto a 25 x 10 mm equipment rail and is supplied via a NIST connection with vacuum from a terminal unit connected using a connection tube with gas probe.
- **Version C:** Tapping unit with equipment mount and NIST connection. FINA VAC B 800 is designed for mounting onto an equipment carrier and is supplied via a NIST connection with vacuum from a terminal unit connected using a connection tube with gas probe.
- **Version D:** Tapping unit for screw connection, with NIST connection. FINA VAC B 800 is designed for direct screw mounting onto mobile suction units (intensive care trolley / surgical trolley) and compact suction units (solo carrier frame) and is supplied with vacuum from a terminal unit via a NIST connection with a connection tube and gas probe.

Products and accessories are only permitted with ISO colour coding. In Germany, Austria and Switzerland, products with neutral colour coding are also permitted.



NOTE

The products are supplied with ISO coding. The scope of delivery includes a label for neutral colour coding.

The product is available in the following versions:

- FINA VAC B 800 Wall MEDAP (REF 5752 3721)
- FINA VAC B 800 Wall DIN (REF 5752 3722)
- FINA VAC B 800 Wall equipment rail (REF 5752 3723)
- FINA VAC B 800 Equipment rail, top view (REF 5752 3725)
- FINA VAC B 800 Screw mount, top view (REF 5752 4866)
- FINA VAC B 800 GT / SS Fresenius (REF 5752 2521)

1.6.5 Interface description

All devices and accessories which are combined with the tapping unit must be listed in the accessories list or meet the specifications of the interface description. Configuration of the overall system as well as functional testing are subject to the overall responsibility of the medical staff. Functionality and suitability of the connected accessory for each intended application must be checked by the operator before every use. This includes the functionality of the connector components, airtightness and suitability regarding material properties, working pressure and flow rate.

1.6.5.1 Vacuum connection tube

The vacuum connection tube is used to connect the tapping unit and the septic fluid jar.

Technical specifications

- Shore hardness of 60
- Inner diameter 6 mm
- Length 50 cm (\pm 10 cm)
- Vacuum resistant down to -95 kPa (must not collapse)

Prerequisites

- The inner diameter of the vacuum connection tube should match the outer diameter of the tube connector on the septic fluid jar cap of the pump.

The vacuum connection tube will be referred to only as 'connection tube' below.

1.6.5.2 Hydrophobic bacterial and viral filter

In its function as overflow protection device, the hydrophobic bacterial and viral filter protects the product against the ingress of particles, fluid and foam. In its function as bacterial and viral filter, it protects the product against the ingress of bacteria and viruses.

Prerequisites

- Pore size ≤ 1.0 μm
- The tube connector must match the tube being used.
- The hydrophobic bacterial and viral filter must close tightly against water passage at an absolute pressure of up to 10 kPa.
- If required, observe the direction of flow (see note on the hydrophobic bacterial and viral filter).

1.6.5.3 Septic fluid jar including septic fluid jar cap

The septic fluid jar and septic fluid jar cap are used to collect the secretions extracted.

Prerequisites

- Low leakage.
- Always fasten the septic fluid jar securely.
- The outer diameter of the tube connector on the patient side should match the inner diameter of the suction tube.

1.6.5.4 Suction tube

The suction tube is used to connect the tube connector on the septic fluid jar on the patient side and the fingertip or the utensil.

Technical specifications

- Shore hardness of 60
- Inner diameter of 6 to 8 mm
- Length of 1.3 m to 3.0 m
- Vacuum resistant down to -95 kPa (must not collapse)

Prerequisites

- The outer diameter of the tube connector on the patient side of the septic fluid jar cap must match the inner diameter of the suction tube.

1.6.5.5 Fingertip

The fingertip serves to vent the suction tube in order to be able to quickly interrupt the aspiration process.

Prerequisites

- It must be possible to sterilise the fingertip or it must be a sterilised disposable item.
- The outer diameter of the tube connector on the patient side should match the inner diameter of the suction tube.

1.6.5.6 Utensil

Suction catheters or lances, for example, are referred to as utensils. The utensils are used to extract septic fluids.

Prerequisites

- The inner diameter of the utensil's connector must match the outer diameter of the fingertip.
- The utensil must be sterilisable or a sterile single-use item.
- Biocompatibility
- For endobronchial extraction, a utensil with side openings must be used.

1.6.5.7 Mechanical overflow protection

The mechanical overflow protection device protects the product against the ingress of fluids. The tube connector must match the vacuum connection tube.

2 Safety notes

2.1 General safety notes

**WARNING!**

Risk of injury!
Hazard resulting from incorrect handling.

Be absolutely sure to observe the operating instructions for all the products used in the configuration.

**WARNING!**

Risk of injury!
ATMOS products may be used only when fully functional.

Ensure that this ATMOS product is fully functional and in good working order prior to use. ATMOS recommends always having another aspirator ready to hand. This enables aspiration even in the event of product failure.

**CAUTION!**

ATMOS recommends always having another aspirator ready to hand. This enables aspiration even in the event of product failure.

2.2 Product safety notes

**DANGER!**

Danger to life!
The product is not suitable for drainage and thoracic drainage. Usage in combination with disposable thoracic drainage systems with integrated vacuum regulation is excepted.

**DANGER!**

Infection hazard due to oversuction!
To avoid the ingress of fluid or foam into the product or the vacuum source, a hydrophobic filter must be used. If secretion enters the inside of the unit, the product must immediately be taken out of operation. Clean and disinfect the product and have it repaired by a service technician authorised by ATMOS to do so.

**DANGER!**

Infection hazard due to contamination!
To avoid the ingress of contaminants into the product or the vacuum source, a bacterial and viral filter must be used. If bacteria or viruses enter the inside of the unit, the product must immediately be taken out of operation. Clean and disinfect the product and have it repaired by a service technician authorised by ATMOS to do so.

**DANGER!**

Risk of injury to mucous membranes!

Endobronchial aspiration in paediatrics and neonatology requires particularly careful limitation of the vacuum. For the regular endobronchial aspiration in paediatrics and neonatology, ATMOS also offers paediatric versions with a higher level of setting convenience.

**WARNING!**

Impacts!

Impacts may cause damage to sensitive, precision mechanical components.
Do not expose the product to impacts.

**WARNING!**

Non-permissible load!

If the permissible load is exceeded, leakages may occur at the connection between the terminal unit and the gas probe.

In accordance with DIN EN ISO 9170-1, the overall weight of the product and accessories may not exceed 2 kg.

**WARNING!**

Foaming!

Foam may be created when extracting secretion. Foam is detrimental to the functioning of the mechanical overflow protection. This raises the risk that secretion may penetrate the product and cause it to break down.

Use an ordinary foam inhibitor.

**WARNING!**

Measuring accuracy / oversuction!

The product may only be operated in a vertical position.

**WARNING!**

Backflow of aspirated secretion!

In the event of oversuction, the aspirated secretion may flow back to the patient if there is secretion still left in the suction tube.

Before replacing the septic fluid jar in the event of oversuction or switching off the vacuum, always remove the tube from the patient first.

**WARNING!**

Risk of injury!

Replace the hydrophobic bacterial and viral filter immediately if it is discoloured, contaminated or oversucked.

Furthermore, the filter must be changed if the vacuum displayed is above -0.3 bar / -30 kPa when the vacuum controller is in the 'max' position and the suction tube is open.

**WARNING!**

Risk of injury!

The product may **not** be used for the following purposes or under the following conditions:

- Never throw, hit or drop the unit.
 - The product is not suitable for vacuum extraction.
 - The product may not be used without a hydrophobic filter.
 - The product may not be used without a bacterial and viral filter.
 - The product may not be used without a septic fluid jar.
 - The product may not be used without a fingertip.
 - Do not hold or lift the product by the vacuum gauge.
 - The vacuum gauge is not autoclavable.
 - During storage, the unit should be protected against damage by using cloths, for example.
-

3 Initial operation

3.1 Equipment inspection

**DANGER!**

Product inspection!

Only product parts which are in perfect condition can ensure proper functioning of the product. The product parts will thus have to be carefully inspected before mounting.

**WARNING!**

Infection hazard!

Contaminated components may endanger the health of staff and patients.

Ensure the product is prepared as per hygiene standards before using it for the first time.

**NOTE**

In order to ensure the functionality, carry out a function check prior to use.

3.2 Mounting

3.2.1 Mounting the vacuum gauge

**NOTE**

The vacuum gauge connection is pressure range specific. If it is not possible to assemble the vacuum gauge, check the scale maximum and the unit designation to see whether the parts can actually match.

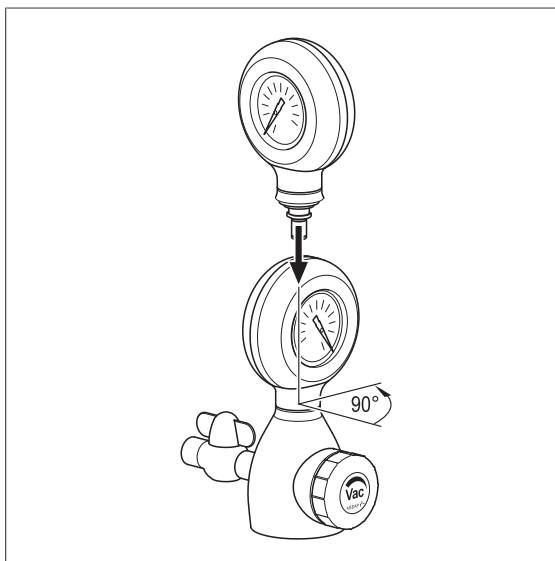

☒ Insert the vacuum gauge into the basic unit with a 90° twist and press downwards until it stops. Turn the vacuum gauge by 90° to the front to lock it.

Fig. 3: Mounting the vacuum gauge

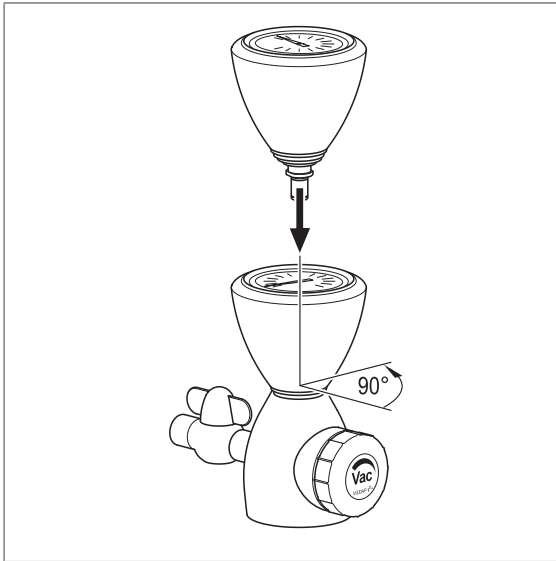

Fig. 4: Mounting the top view vacuum gauge

3.2.2 Connection to the terminal unit

3.2.2.1 General



NOTE

Please refer to the manufacturer's instructions for the particular terminal unit for information on connecting the gas probe to the terminal unit.

3.2.2.2 Version A

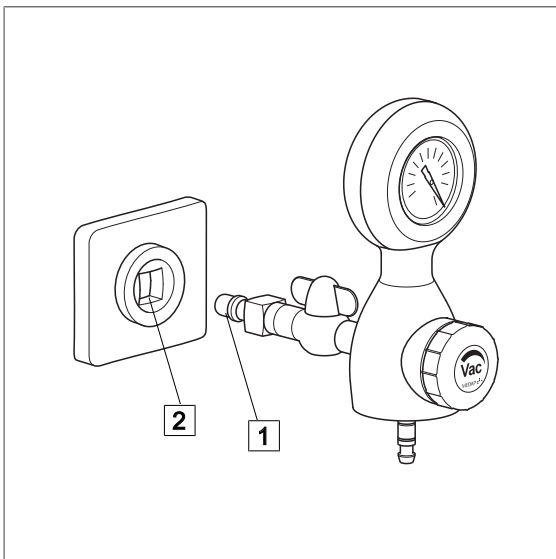

Fig. 5: Version A

Tapping unit with integrated gas pin

The tapping unit (1) is plugged directly into the terminal unit (2).

3.2.2.3 Version B

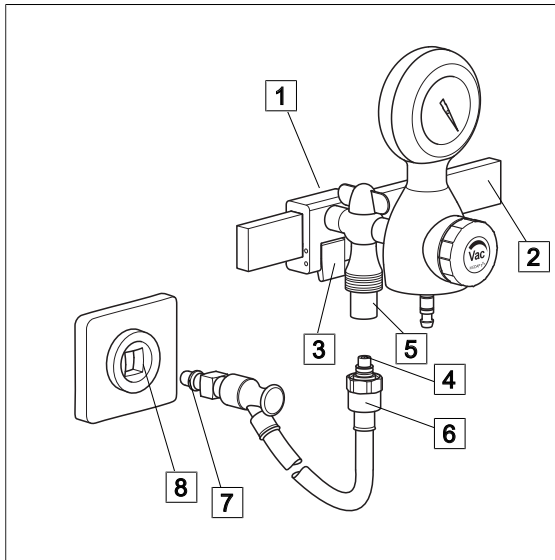

Fig. 6: Version B

Tapping unit with rail clamp and NIST connection

- ☒ With the upper edge of the guide groove at the front, position the rail clamp (1) at a slight angle on the equipment rail (2) and then press it against the equipment rail and allow it to click into place.
- ☒ Make sure that the rail clamp is correctly secured and that the tapping unit is in a stable position on the equipment rail. The locking lever (3) must be flush with the rail clamp.
- ☒ Insert the NIST nipple (4) of the connection tube into the NIST connection (5) of the tapping unit and tighten down the NIST screw connection (6) by hand.
- ☒ Plug the gas probe (7) of the connection tube into the terminal unit (8).

3.2.2.4 Version C

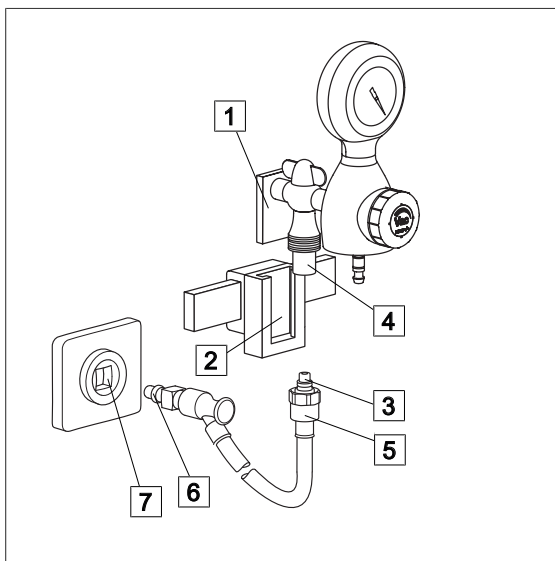

Fig. 7: Version C

Tapping unit with equipment mount and NIST connection

- Please refer to the manufacturer's instructions for the equipment carrier.
- ☒ Insert and lock the equipment mount (1) of the tapping unit in the designated equipment carrier (2).
 - ☒ Make sure that the equipment mount (1) is completely inserted into the equipment carrier (2) and the tapping unit is in a stable position in the equipment carrier (2).
 - ☒ Insert the NIST nipple (3) of the connection tube into the NIST connection (4) of the tapping unit and tighten down the NIST screw connection (5) by hand.
 - ☒ Plug the gas probe (6) of the connection tube into the terminal unit (7).

3.2.2.5 Version D

The tapping unit for screw connection may be connected to an intensive care trolley, surgical trolley or solo aspiration set carrier frame. The carrier frame is used to show the assembly.

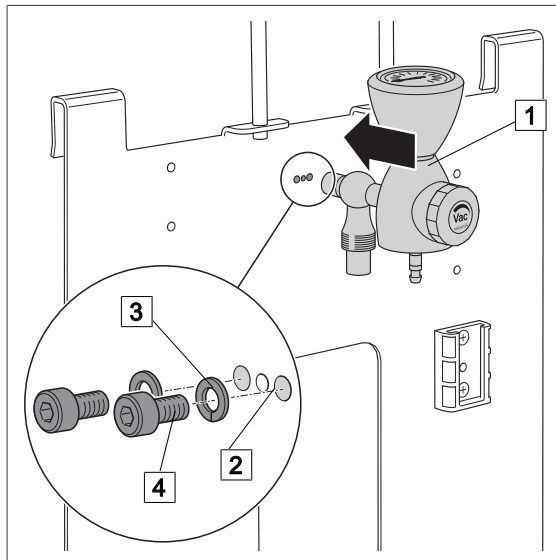

Fig. 8: Version D

Tapping unit for screw connection, with NIST connection

- ☒ Press the tapping unit (1) up against the carrier frame.
 - ✓ The drilled holes of the tapping unit are positioned over the drilled holes (2) of the carrier frame.
- ☒ Put the lock washers (3) onto the hexagon screws (4).
- ☒ Use the hexagon screws to screw the tapping unit into place.

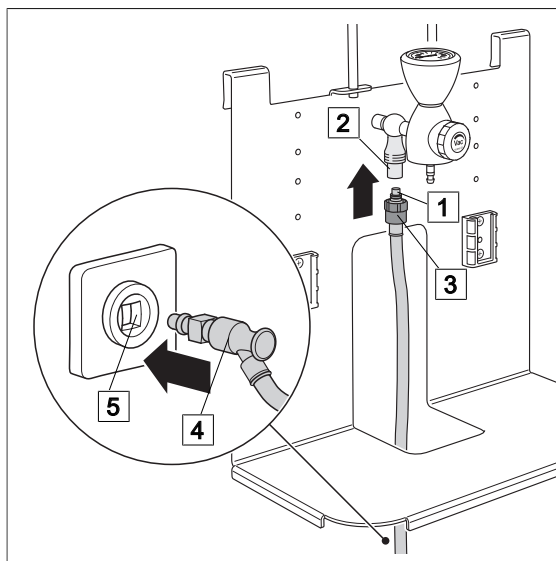

Fig. 9: Connection tube

- ☒ Insert the NIST nipple (1) of the connection tube into the NIST connection (2) of the tapping unit and tighten down the NIST screw connection (3) by hand.
- ☒ Plug the gas probe (4) of the connection tube into the terminal unit (5).

3.2.3 Assembly of the septic fluid jar and accessories



WARNING!

Tensile forces!

The connected accessories must not exert any mechanical forces which could adversely affect the secure fit of the product.



WARNING!

Tensile forces!

Hold the basic unit with one hand when installing or removing accessories in order to compensate for the tensile forces which are created.



NOTE

Refer to the manufacturer's instructions for additional information on the use of the septic fluid jar and the extraction utensil.

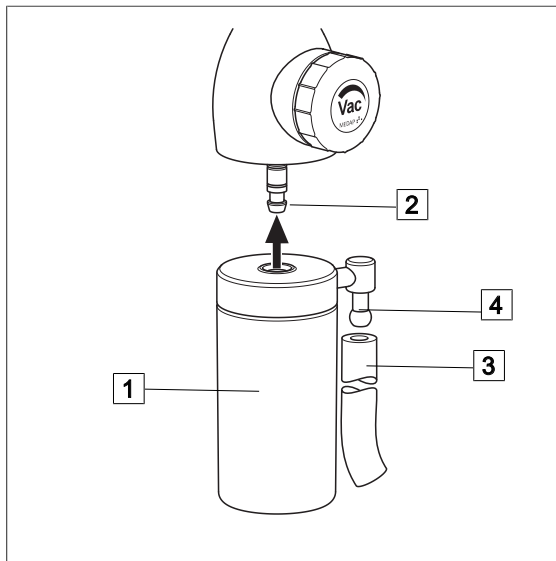

Fig. 10: Connection of the mechanical overflow protection

Connection of the mechanical overflow protection

- ☒ Plug the overflow protection device (1) directly onto the tube connector (2) on the housing of the tapping unit and press upwards until it stops.
- ☒ Attach the connection tube (3) to the tube connector (4) of the mechanical overflow protection device and to the designated tube connector of the septic fluid jar.
- ☒ For disassembly, first remove the connection tube from the tube connector of the mechanical overflow protection device. Then remove the complete overflow protection device with lid from the tube connector of the tapping unit. Hold the tapping unit steady with one hand while doing so.

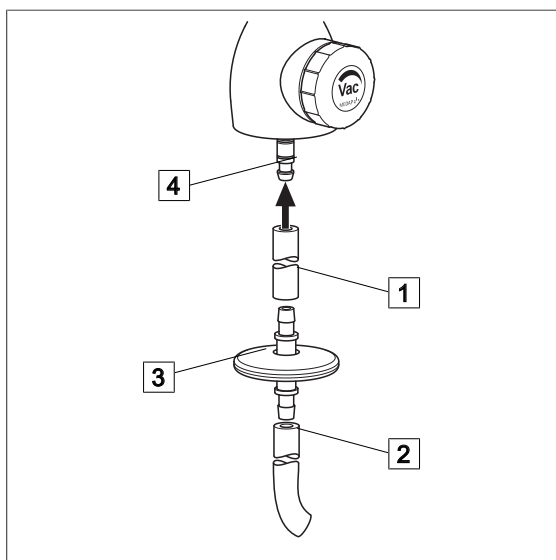

Fig. 11: Connection of the hydrophobic bacterial and viral filter

Connection of the hydrophobic bacterial and viral filter

- ☒ The connection tubes (1) and (2) are plugged onto the tube connectors of the hydrophobic bacterial and viral filter (3).
- ☒ Check the flow direction of the bacterial and viral filter. The inlet side must face the patient, and the outlet must face the tapping unit.
- ☒ Then plug the connection tube onto the tube connector (4) on the housing of the tapping unit.
- ☒ Connect the connection tube with the designated tube connector of the septic fluid jar.

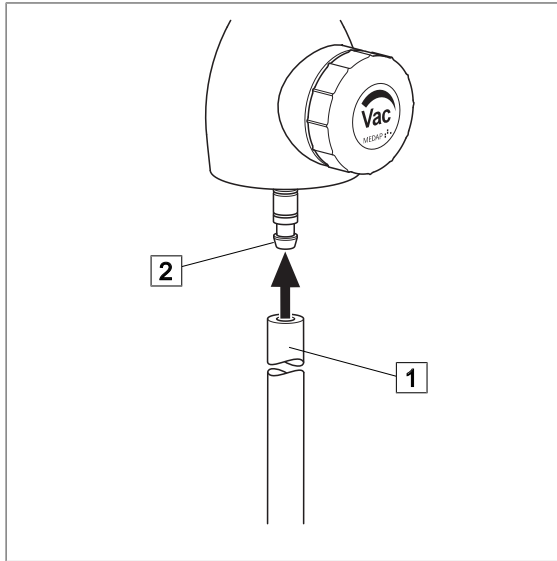

Fig. 12: Connection of the septic fluid jar

Connection of the septic fluid jar with integrated hydrophobic bacterial and viral filter

- Attach the connection tube (1) to the tube connector (2) on the housing of the tapping unit and to the tube connector of the septic fluid jar.

4 Operation

4.1 Function test



DANGER!

Function check!

The product is used in the treatment of patients. Any restriction in the unit's performance can result in serious complications in treatment.

Perform a complete function check every time before using the unit.



NOTE

Connecting several septic fluid jars in series can cause delayed suction effect and reduced flow rate.

Prior to each use, carry out the following function checks:

Version A: Tapping unit with integrated gas pin

- The tapping unit is correctly plugged into the terminal unit.

Version B: Tapping unit with rail clamp and NIST connection

- The tapping unit is locked firmly to the equipment rail.

Version C: Tapping unit with equipment mount and NIST connection

- The tapping unit is correctly plugged into the equipment carrier.

Version D: Tapping unit for screw connection, with NIST connection

- Tapping unit is firmly screwed to the intensive care trolley, surgical trolley or aspiration set carrier frame solo.

All versions:

- The product has been properly cleaned and neither residue nor contamination are present.
- The control valve can be easily turned and the shut-off valve is functioning.
- The overflow protection device and the hydrophobic bacterial and viral filter are mounted, fully functional and no residue is trapped in it.
- The tube connectors are firmly secured and tightly sealed, and no mechanical forces are acting on the tubes.
- The plastic and rubber product parts are in perfect condition and show no signs of ageing.
- A septic fluid jar is connected to the tapping unit.

4.2 Working with the product



DANGER!

Infection hazard!

In the event of oversuction, the hydrophobic bacterial and viral filter must no longer be used.

Replace the hydrophobic bacterial and viral filter with a new one.



WARNING!

Vacuum setting!

Make the vacuum settings very carefully! The regulating mechanism is sensitive.



WARNING!

Air inlet!

The drill hole on the underside of the unit must always be kept free so that airflow is always ensured.



NOTE

Check the vacuum setting once again immediately before using the unit!

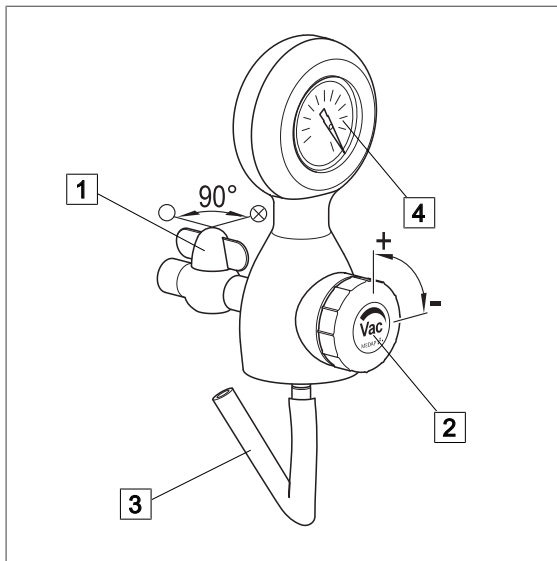

Fig. 13: Setting the vacuum level

Setting the vacuum for treatment

- ☒ Open the shut-off valve (1) completely for operation. For this purpose, turn the valve by 90° so that it is in line with the gas supply.
- ☒ Close the control valve (2) until it stops. Turn in a clockwise direction.
- ☒ Bend the connection tube (3) leading to the septic fluid jar and set the vacuum with the control valve while doing so. Turn anticlockwise. Read the value on the vacuum gauge (4). Should it not be possible to shut off or increase the vacuum as required, refer to the troubleshooting table to find the cause.
- ☒ Use the control valve to set the required value for the treatment.
 - Increase the vacuum:** Turn the control valve anticlockwise.
 - Reduce the vacuum:** Turn the control valve clockwise.

5 Taking the unit out of operation

5.1 Completing the aspiration process

**NOTE**

Please refer to the manufacturer's instructions for the particular terminal unit for information on detaching the gas probe from the terminal unit.

- Remove the suction tube from the patient.
- Close the shut-off valve and the control valve.
- Empty the septic fluid jar and recondition or replace it.
- Remove the connection tubes and the overflow protection device / the hydrophobic bacterial and viral filter from the tapping unit and from the septic fluid jar and recondition or discard them.
- Clean the components.
- Disconnect the gas probe from the terminal unit.

Version B: Tapping unit with rail clamp and NIST connection

- Remove the product from the equipment rail. For this purpose, pull the locking lever and lift the product off the equipment rail.

Version C: Tapping unit with equipment mount and NIST connection

- Disconnect the product from the equipment carrier.

6 Cleaning and disinfection

6.1 General

The product must be wipe or spray disinfected after every use.

**DANGER!**

Risk due to incorrect use of detergents and disinfectants!

It is strictly advised to observe the manufacturer's instructions regarding how to use the detergents and disinfectants as well as to observe the valid hospital hygiene rules.

**DANGER!**

Infection hazard!

Product may be contaminated.

Always wear gloves for cleaning and disinfection.

**DANGER!**

Infection hazard!

Particles of grime may become encapsulated and lead to the product not reaching the desired germ reduction after disinfection.

Before disinfection, the product must be cleaned thoroughly of contamination and encapsulated particles of grime.

**CAUTION!**

Improper cleaning and disinfection can cause property damage!

Do **not** use the following products for cleaning and disinfection:

- Products containing alcohol (e.g. hand disinfectants)
- Halogenides (e.g. fluorides, chlorides, bromides, iodides)
- Dehalogenating compounds (e.g. fluorine, chlorine, bromine, iodine)
- Products that may scratch the surface (e.g. scouring agents, wire brushes, wire wool)
- Standard commercial solvents (e.g. benzene, thinner)
- Water containing iron particles
- Cleaning sponges containing iron
- Products containing hydrochloric acid

Use a soft, lint-free cloth or a soft nylon brush to clean the product.

**CAUTION!**

Improper cleaning and disinfection can cause property damage!

Use only as much detergent and disinfectant as required.

**CAUTION!**

Improper cleaning and disinfection can cause property damage!

After each cleaning and disinfection process, carry out the functionality test.

6.2 Cleaning

6.2.1 General



NOTE

Use only all-purpose cleaners which are slightly alkaline (soap solution) and contain surfactants and phosphates as the active cleaning agents.

In the event of heavily contaminated surfaces, use concentrated all-purpose detergent.



CAUTION!

Improper cleaning can cause property damage!

Residues of physiological saline solutions (e.g. sodium chloride) can attack the surfaces of the product.

Remove residues of physiological saline solutions with a cloth dampened in clean water. Then dry the product with a dry, lint-free cloth.



CAUTION!

Improper cleaning can cause property damage!

Do not spray cleaning agent directly into the joints or gaps and never use a high-pressure cleaning unit!

6.2.2 Cleaning procedure

- Use the correct dose of all-purpose detergent with water for the degree of surface contamination and in accordance with the instructions of the detergent manufacturer.
- Thoroughly wipe off the product with a soft cloth slightly dampened in an all-purpose detergent solution.
- Ensure that the product is free of contamination and encapsulated particles of grime.
- Thoroughly wipe off the product with a soft cloth slightly dampened in clean water.
- Ensure that the product is free of detergent residues.
- Dry the product with a dry, absorbent and lint-free cloth.
 - ✓ This will help to reduce pathogen growth on the product's surface.
- Wipe disinfect the product after every cleaning process.

6.3 Disinfection

6.3.1 General



NOTE

In the event that product surfaces are very dirty, carry out an additional cleaning procedure before disinfecting.



DANGER!

Reduced performance!

Only clean the product by wipe disinfection.

Ensure that no disinfectants enter the unit.

Check the functionality of the product after each disinfection.

**CAUTION!**

Material damage due to excessive exposure times!

Exceeding the specified exposure time of the disinfectant may damage the surfaces.

Observe the exposure time specified by the disinfectant manufacturer.

6.3.2**Suitable disinfectants**

Only surface disinfectants based on the following combinations of active ingredients may be used for disinfection:

- Aldehydes
- Quaternary ammonium compounds
- Guanidine derivatives

Ingredient group	Active ingredients
Aldehydes	2-ethyl-1-hexanal, formaldehyde, glutardialdehyde, glyoxal, o-phthaldialdehyde, succinaldehyde
Quaternary ammonium compounds	Alkyl-didecyl-polyoxethyl ammonium propionate, alkyl-dimethyl-alkylbenzyl ammonium chloride, alkyl-dimethyl-ethyl ammonium chloride, alkyl-dimethyl-ethylbenzyl ammonium chloride, benzalkonium propionate, benzalkonium chloride (alkyl-dimethyl-benzyl ammonium chloride, coco-dimethyl-benzyl ammonium chloride, lauryl-dimethylbenzyl ammonium chloride, myristyl-dimethyl-benzyl ammonium chloride), benzethonium chloride, benzyl-dihydroxyethyl-coco-alkyl ammonium chloride, dialkyl-dimethyl ammonium chloride (didecyldimethyl ammonium chloride), didecyl-methyl-oxyethyl ammonium propionate, mecetronium-ethyl sulfate, methyl-benzethonium chloride, n-octyl-dimethyl-benzyl ammonium chloride
Guanidine derivatives	Alkyl-biguanide, chlorhexidine-digluconate, cocospropylene-diamine guanidinium diacetate, oligomeric biguanide, polyhexamethylene biguanide hydrochloride (oligo-diimino imido-carbonyl imino-hexamethylene, polyhexanide)

Tab. 4: Active ingredients of disinfectants

6.3.3**Disinfection procedure**

- Wipe disinfect the product in accordance with the instructions of the disinfectant manufacturer after every cleaning process.
- Ensure that the product is free of disinfectant residue.
- Perform visual and functional inspections.

6.3.4**Disinfection procedures**

Different disinfection procedures may be used for the various components depending on the properties of the materials. Before disinfection, remove contamination and residues from the parts and dry well.

Components	Wipe, spray disinfection ¹
FINA VAC B 800	X
Trolley	X
Catheter holder	

¹ After exposure (as prescribed in the manufacturer's instructions), remove disinfectant residues from the components using a moist cloth and dry them afterwards.

6.4 Product-specific safety notes



DANGER!

Health hazard!

The product may not be disassembled for cleaning or disinfection. During cleaning and disinfection, pay attention that no cleaning agent, disinfectant or other contamination is able to enter the product.



DANGER!

Risk to patient!

Oversuction of products results in them no longer being functional. There is considerable risk to the patient if the tapping unit is not cleaned properly after being exposed to oversuction, as safety equipment could be clogged.

After oversuction, products must be dismantled and cleaned thoroughly by authorised service staff.



CAUTION!

Property damage due to sterilisation!

Do not sterilise the product.



CAUTION!

Property damage!

Using non-colour-fast surgical drapes can cause discolouration of surfaces.

Only use colour-fast surgical drapes.



NOTE

For the cleaning and disinfection of versions B and C, disconnect the connection tube with the NIST screw connection from the tapping unit.

7 Maintenance

7.1 General

Maintenance, repairs and periodic tests may only be carried out by persons who have the appropriate technical knowledge and are familiar with the product. To carry out these measures, the person must have the necessary test devices and original spare parts.

ATMOS recommends: Work should be carried out by an authorised ATMOS service partner. This ensures that repairs and testing are carried out professionally, original spare parts are used and warranty claims remain unaffected.



DANGER!

Health hazard!

The product is used in the treatment of patients. The product or some of its components may be contaminated.

Clean and disinfect the product before maintenance and repair. Repair work may be performed by personnel authorised by ATMOS.

7.2 Periodic tests

At least every 5 years a test must be performed.

7.3 Malfunctions and troubleshooting

Defect	Source of malfunction	Corrective actions
<ul style="list-style-type: none"> • No or low vacuum • No or reduced flow rate • Regulation of flow rate not possible 	Shut-off valve is closed	Open the shut-off valve
	No vacuum gauge connected	Attach the vacuum gauge in accordance with the operating instructions
	Connection tube is not connected to tapping unit	Connect connection tube according to operating instructions
	Connection tube too long	Shorten connection tube to a maximum length of 50 cm
	Connection tubes collapse	Use special connection tubes (vacuum proof up to -95 kPa)
	Full septic fluid jar; overflow protection system closed	Empty/replace septic fluid jar; replace overflow protection device
	Oversuction of hydrophobic bacterial and viral filter	Replace hydrophobic bacterial and viral filter
	Seal damaged	Replace seal
	Suction system is leaking	Check suction system
	Shut-off valve defective	Contact Technical Service
	Central supply system failure	
	Gas probe connection is loose	
	Vacuum gauge is defective	
Control valve is defective		

Defect	Source of malfunction	Corrective actions
Vacuum gauge does not fit	An attempt has been made to connect the vacuum gauge to the tapping unit with the scale pointing forwards	Always insert vacuum gauge with a 90° twist and then turn it to the front
	Vacuum gauge for the incorrect pressure range	Select vacuum gauge for the correct pressure range (see type plate); connections are coded
Oversuction of product despite protective system	Tapping unit mounted at an angle	Operate tapping unit in a vertical position only
	Overflow protection device contaminated	Clean/replace the overflow protection device
	No foam inhibitor used	Use standard commercial foam inhibitor
Gas probe does not fit into the terminal unit	Terminal unit for the wrong gas type	Check gas type

7.4 Repairs

The following may require repairs by the manufacturer or an authorised service partner:

- Liquid has penetrated the device.
- Performance has significantly decreased.
- Inexplicable notifications appear.
- Abnormal noises occur.
- Functional faults cannot be rectified according to the measures in chapter Malfunctions and troubleshooting [▶▶ page 30].

If defects are detected, the product may not be used any longer.

Make a note of the defects and the REF number on the type plate and inform your ATMOS representative.

Observe the information in chapter Sending in the device [▶▶ page 31].

7.5 Service hotline

+49 7653 689-0

7.6 Spare parts

5752 2100	Front view vacuum gauge
5752 2101	Top view vacuum gauge

Tab. 5: Spare parts

7.7 Sending in the device

- Remove and properly dispose of consumables.
- Clean and disinfect the product and accessories according to the operating instructions.
- Place used accessories with the product.
- Fill in form QD 434 'Delivery complaint / return shipment' and the respective **decontamination certificate**.

This form is enclosed with each delivery and can be found at www.atmosmed.com.

- The device must be well padded and packed in suitable packaging.
- Place form QD 434 'Delivery complaint / return shipment' and the respective **decontamination certificate** in an envelope.
- Affix the envelope to the outside of the package.
- Send the product to ATMOS or to your dealer.

8 Technical specifications

8.1 General

Classification as per Annex IX to Directive 93/42/EEC	Class IIa
---	-----------

8.2 Ambient conditions

Temperature: Shipping / storage	-15 °C to +50 °C
Temperature: Operation	+10 °C to +40 °C
Relative humidity: Shipping / storage	10% to 95%
Relative humidity: Operation	30% to 75%
Atmospheric pressure: Shipping / storage	700 hPa to 1060 hPa
Atmospheric pressure: Operation	700 hPa to 1060 hPa

8.3 Technical specifications

Nominal pressure, gas supply	-100 kPa to -60 kPa*
Vacuum regulation range (depending on the nominal pressure of the gas supply)	0 to -80 kPa*
Flow rate (freeflow)**	min. 50 l/min
Vacuum gauge	Accuracy class 2.5
Year of manufacture	First two digits of the serial number

* 100 kPa = 1 bar = 1000 mbar = 750 mmHg

** in accordance with EN 10079-3. Depending on the design of the gas supply system, the actual performance of the tapping unit may be reduced.

8.4 Dimensions

Dimensions with vacuum gauge (L x W x H)	165 x 72 x 170 mm
Dimensions with top view vacuum gauge (L x W x H)	165 x 72 x 140 mm

8.5 Weight

Weight	1100 g
--------	--------

9 Approved accessories

9.1 Standard scope of delivery

5750 3779	Neutral colour coding label
-----------	-----------------------------

Tab. 6: Standard scope of delivery

9.2 Accessories

5752 5365	FINA mobile suction unit basic equipment / vacuum
5752 5367	FINA mobile suction unit complete unit / vacuum / 2 x 3 l
5752 5260	FINA compact suction unit basic equipment / vacuum
5752 5262	FINA compact suction unit complete unit / vacuum / 2 x 1 l
5752 1698	Mechanical overflow protection
5752 3330	Aspiration set for equipment rail / 1 l
5752 5669	Aspiration set for wall mount / 1 l
5752 5256	Aspiration set carrier frame solo
5752 5288	Equipment carrier for aspiration set carrier frame solo
5752 5314	Surgical trolley
5750 8021	Tube holder
	VAC connection tube with NIST screw connector (see MEDAP tube list)

Tab. 7: Accessories

9.3 Accessories for compact suction unit / basic vacuum equipment

The suction units can be used in combination with the following application sets.

5752 5645	AS septic fluid aspiration / 2 x 1 l / reusable
-----------	---

Tab. 8: Accessories for compact suction unit / basic vacuum equipment

9.4 Accessories for mobile suction unit / basic vacuum equipment

The suction unit can be used as a surgical aspirator by combining it with the following application sets.

5752 2067	AS surgical aspiration / 2 x 5 l
5752 5664	AS surgical aspiration / 2 x 4 l / PSU
5652 5665	AS surgical aspiration / 2 x 4 l / PC
5752 2068	AS surgical aspiration / 2 x 3 l
5752 4940	AS surgical aspiration / 2 x 3 l / Serres®
310.0401.0	Serres® disposable suction liner 3 l, with gelling agent (20 pieces)
310.0411.0	Serres® disposable suction liner 3 l, without gelling agent (24 pieces)
5752 2049	Vacuum shift
5752 4538	Bowl for trolley

Tab. 9: Accessories for mobile suction unit / basic vacuum equipment

9.5 Consumables

5750 0630	Hydrophobic bacterial and viral filter
006.0009.0	Suction tube, silicone, Ø 6 mm, 1 m
000.0347.0	Fingertip

Tab. 10: Consumables



■ **Manufacturer:**

ATMOS
MedizinTechnik GmbH & Co. KG
Ludwig-Kegel-Str. 16
79853 Lenzkirch
GERMANY
Telephone: +49 7653 689-0
www.atmosmed.com