

Operating Instructions

ATMOS S 61

CORIAN®

instruments

ATMOS S 61

CORIAN® integral

English

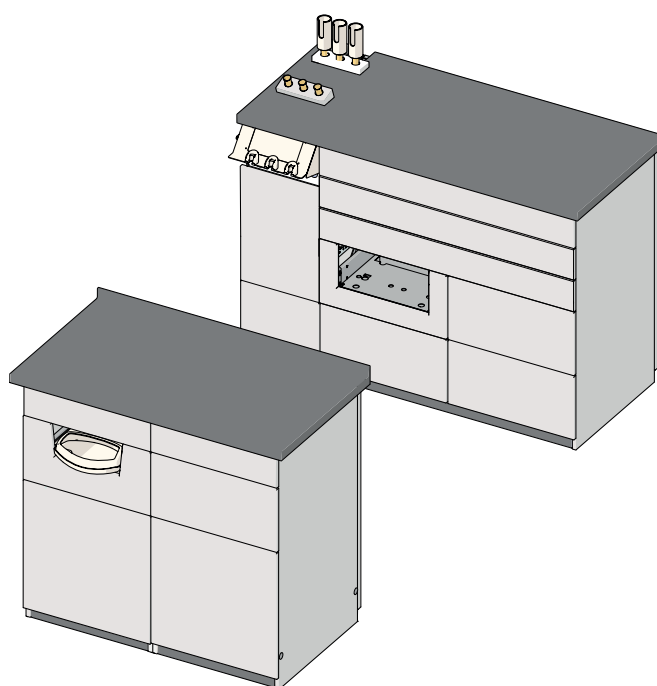

## Table of contents

<b>1</b>	<b>Introduction.....</b>	<b>4</b>
1.1	Notes on operating instructions .....	4
1.2	Explanation of pictures and symbols .....	5
1.3	Intended use.....	6
1.4	Function.....	8
1.5	Scope of delivery .....	8
1.6	Transport and storage .....	9
<b>2</b>	<b>Notes for your safety.....</b>	<b>10</b>
2.1	General safety instructions.....	10
2.2	Danger for users, patients, and third parties .....	10
2.3	Avoiding damage to the device .....	11
<b>3</b>	<b>Setting up and starting up .....</b>	<b>12</b>
3.1	Device overview.....	12
3.2	Preparing the device .....	12
<b>4</b>	<b>Operation.....</b>	<b>13</b>
4.1	Ambient conditions during operation .....	13
4.2	Switching on the device (ATMOS S 61 CORIAN® integral).....	13
4.3	Switching off the device (ATMOS S 61 CORIAN® integral).....	13
4.4	Using the drawers .....	13
4.5	Using the drawer for devices (optional) .....	14
4.6	Inserting and removing the instrument disposal tray (optional) .....	14
4.7	Using the waste disposal (optional).....	14
4.8	Using light sources (optional) .....	15
4.8.1	Connecting the fiber optic light cable .....	15
4.8.2	Removing the fiber optic light cable .....	15
4.8.3	Changing the adapter.....	15
4.8.4	Switching on the light source .....	15
4.8.5	Adjusting brightness.....	15
4.8.6	Stroboscopy capability of the light source (optional) .....	16
4.9	Storing endoscopes (optional).....	17
<b>5</b>	<b>Cleaning and disinfection .....</b>	<b>18</b>
5.1	Reprocessing the product .....	18
5.1.1	Reprocessing the endoscope quivers .....	18
5.1.2	Reprocessing the instrument disposal trays .....	18
5.1.3	Reprocessing the instrument trays .....	19
5.1.4	Reprocessing the fiber optic light cables .....	19
5.1.5	Reprocessing the surfaces.....	19
5.2	Recommended disinfectants .....	20
5.2.1	Surface disinfectants .....	20
5.2.2	Instrument disinfectants.....	21
<b>6</b>	<b>Hygiene plan.....</b>	<b>23</b>

<b>7</b>	<b>Maintenance and service</b> .....	<b>25</b>
7.1	Periodic tests .....	25
7.2	Function check.....	25
7.3	Sending in the device.....	26
<b>8</b>	<b>Troubleshooting</b> .....	<b>27</b>
<b>9</b>	<b>Accessories</b> .....	<b>28</b>
<b>10</b>	<b>Disposal</b> .....	<b>29</b>
<b>11</b>	<b>Technical data</b> .....	<b>30</b>
<b>12</b>	<b>Notes on EMC</b> .....	<b>33</b>

# 1 Introduction

## 1.1 Notes on operating instructions

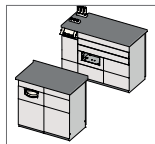

These operating instructions contain important instructions on how to operate your product safely, correctly, and effectively.

These operating instructions are designed for training and instructing new operating personnel in the use of the system, and also for use as a reference manual. This document may only be reprinted, either in part or in whole, with written permission from ATMOS.

**These operating instructions must always be kept to hand near the device.**



Care, periodic tests, regular cleaning, and proper application are essential. They ensure the operational safety and usability of the product.

Maintenance, repairs, and periodic tests may only be carried out by persons who have the appropriate technical knowledge and are familiar with the product. The person in question must possess the necessary test devices and original spare parts required to carry out these measures.



Read chapter "2 Notes for your safety" on page 10 before using the product for the first time. This will help you to avoid potentially dangerous situations.

The product bears the CE marking CE in accordance with the European Medical Device Regulation (MDR) 2017/745.

The product complies with all the applicable requirements of Directive 2011/65/EC on the restriction of the use of certain hazardous substances in electrical and electronic equipment ("RoHS").

The Declarations of Conformity and our General Terms and Conditions can be viewed on our website at [www.atmosmed.com](http://www.atmosmed.com).

The quality management system at ATMOS has been certified according to international standard EN ISO 13485.









These operating instructions are valid for the following devices:

- |                                      |            |
|--------------------------------------|------------|
| • ATMOS S 61 CORIAN® integral        | 532.0800.0 |
| • ATMOS S 61 CORIAN® instruments     | 532.1000.0 |
| • ATMOS S 61 CORIAN® instruments XXL | 532.0900.0 |







Corian® is a registered trademark of E. I. du Pont de Nemours and Company or its affiliated companies.













## 1.2 Explanation of pictures and symbols

### In the operating instructions

 <b>DANGER</b>	Warning of a danger that will result in immediate fatal or serious injury. Observe the necessary measures.
 <b>WARNING</b>	Warning of a danger that can cause fatal or serious injury. Observe the necessary measures.
 <b>CAUTION</b>	Warning of a danger that can cause minor injury. Observe the necessary measures.
<b>NOTICE</b>	Notice of a danger that can damage the product or other objects. Observe the necessary measures.
	Warning of a danger that can cause fatal or serious injury.
	Notice of potential material damage.
	Useful information on the handling of the device.
1.	Action. Proceed step by step.
»	Result of an action.
	Move, plug in this direction.
	Engage, check correct fit.

### On device, type plate, and packaging

	Follow operating instructions (blue)
	Consult operating instructions
	Warning; pay special attention
	This device complies with the relevant requirements of EU regulations.
	This device complies with the relevant requirements of the Eurasian Economic Union.
	Manufacturer
	Date of manufacture Country of manufacture
<b>REF</b>	Reference number

	Unique Device Identifier of a medical device
	Medical device
	Serial number
	Professional disposal
	Fuse
	Alternating current (only with Servo-Drive® option)
	This side up
	Fragile, handle with care
	Keep dry
	Keep away from sunlight
	Temperature limit
	Humidity limitation
	Atmospheric pressure limitation

### UDI application identifier

- (01) UDI-DI: Identification of the manufacturer and the device
- (11) Date of manufacture
- (21) Serial number

## 1.3 Intended use

**Product name:** **ATMOS S 61 CORIAN® instruments**  
**ATMOS S 61 CORIAN® instruments XXL**

**Main functions:**

- Instrument storage and deposit.
- For expansion of the ATMOS S 61 Servant ENT workstation.

**Intended purpose:** Standard ENT examination and / or therapy

**Intended Users / User profile:** Doctors and medical specialists

<b>Intended Patient population:</b>	All patients without any restrictions
<b>Medical conditions to be diagnosed, treated or monitored:</b>	Diagnostic examination of anatomy of all kinds
<b>Application organ:</b>	Ear, Nose, Throat
<b>Application time:</b>	< 60 min.
<b>Application site:</b>	Outpatient medical facilities, e.g. ENT practices, hospital outpatient departments, medical care centers
<b>Indications:</b>	Standard ENT examination and / or therapy
<b>Medical contra-indications:</b>	None
<b>The product is:</b>	active
<b>Sterility/specific microbial status:</b>	Not sterile
<b>Single use product / reprocessing:</b>	Not a single use product. Reprocessing according to instructions for use.
<b>Name:</b>	<b>ATMOS S 61 CORIAN® integral</b>
<b>Main functions:</b>	<ul style="list-style-type: none"> <li>• Electric power supply for visualization, illumination and illumination accessories</li> <li>• Instrument storage and deposit</li> </ul>
<b>Intended purpose:</b>	Standard ENT examination and / or therapy
<b>Intended users / User profile:</b>	Doctors and medical specialists
<b>Intended Patient population:</b>	All patients without any restrictions
<b>Medical conditions to be diagnosed, treated or monitored:</b>	Diagnostic examination of anatomy of all kinds
<b>Application organ:</b>	Ear, Nose, Throat
<b>Application time:</b>	< 60 min.
<b>Application site:</b>	Outpatient medical facilities, e.g. ENT practices, hospital outpatient departments, medical care centers
<b>Indications:</b>	Standard ENT examination and / or therapy
<b>Medical contra-indications:</b>	None
<b>The product is:</b>	active
<b>Sterility/specific microbial status:</b>	Not sterile
<b>Single use product / reprocessing:</b>	Not a single use product. Reprocessing according to instructions for use.

## 1.4 Function

The products ATMOS S 61 CORIAN® instruments, ATMOS S 61 CORIAN® instruments XXL, and ATMOS S 61 CORIAN® integral are cabinets for storing and organizing instruments, diagnostic and therapeutic devices, and visualization devices for ear, nose and throat specialists. The workspace as well as the options and accessories can be individually configured by the user according to his or her personal needs. The drawers can be fitted with optional electronic assistance for opening and closing (Servo-Drive®). The device is used in hospitals/clinics or in ENT practices.

The product ATMOS S 61 CORIAN® integral offers additional storage space for ATMOS diagnostic equipment and ATMOS visualization equipment. The product also offers storage space for an optional light source and either heated or non-heated endoscope holders. Reprocessed endoscopes can be stored for short periods of time.

## 1.5 Scope of delivery

### ATMOS S 61 CORIAN® instruments

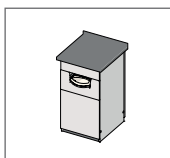

ATMOS S 61  
CORIAN®  
instruments



Operating instruc-  
tions

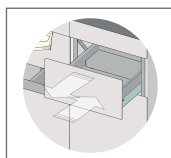

Servo-Drive®



Operating instructions  
Servo-Drive®

### ATMOS S 61 CORIAN® instruments XXL

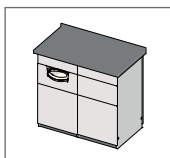

ATMOS S 61  
CORIAN®  
instruments XXL



Operating instruc-  
tions

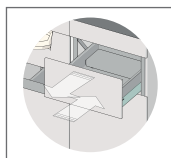

Servo-Drive®

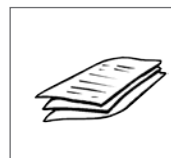

Operating instructions  
Servo-Drive®

### ATMOS S 61 CORIAN® integral

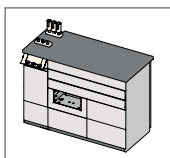

ATMOS S 61  
CORIAN®  
integral



Operating  
instructions



Isolation  
transformer



Isolation  
transformer  
operating  
instructions



Servo-Drive®



Operating  
instructions  
Servo-Drive®



## 1.6 Transport and storage

Only transport the device in a shipping carton that is padded and offers sufficient protection.

If damage occurs during transport:

1. Document and report the transport damage.
2. Send the device to ATMOS; see chapter "7.3 Sending in the device" on page 26.

### **Environmental conditions for transport and storage:**

- Temperature: -10...+50 °C
- Air humidity without condensation: 30...95 % without condensation
- Air pressure: 500...1060 hPa

## 2 Notes for your safety

Please read and pay attention to the safety instructions prior to using the product.

### 2.1 General safety instructions

Report all serious incidents that have occurred in connection with this device to the manufacturer and your national competent authority.

Only use accessories and options that are specifically suited for combination with the product and that meet the performance and safety requirements.

If you wish to connect more than one device or applied part, you must always observe their safety instructions.

#### CAUTION

The device may only be transported when the drawers are secured against sliding out. Otherwise, the device may tip over.

#### CAUTION

Servo-Drive® may only be used in dry and closed rooms. Never place open containers of liquids in the cabinets.

#### CAUTION

The drawers may only be filled with a maximum load of **4.5 kg**.

#### CAUTION

Please note that the light source will illuminate even if it is not connected to a fiber optic light cable.

### 2.2 Danger for users, patients, and third parties

#### **Risk of infection due to patient secretion on the device!**

Risk of diseases being transmitted.

- Always wear disposable gloves if there is a risk of you coming into contact with secretions.
- Do not set contaminated instruments or endoscopes down in areas other than those specifically designated for this purpose.
- Clean heating modules regularly and disinfect if necessary; only heat clean instruments.
- Clean and disinfect the product according to the operating instructions.

#### **Danger of blinding due to the high light intensity.**

Eye injury is possible. There is a risk of blinding for people without a blink reflex or who are particularly sensitive to light.

- The light source may only be operated by qualified personnel.
- Never look directly into the light source.
- Never direct the light source into the patient's eyes.
- Never allow the patient to look into the light source.

### **Heat development of the light source.**

Risk of burns.

- Temperature control of the instruments by the user, e.g., on the back of the hand.
- Pay attention to the heat development of the light source.
- Switch off the light source when not in use.
- Never reach into the light source output.

### **Avoid improper use.**

Risk of severe injury to your patient.

- The product is only permitted for use by trained, specialist personnel under supervision.
- The product may only be applied by medically trained staff.

### **Keep the device fully functional at all times.**

Malfunctions could cause injury to you and your patients.

- Prior to each use, check whether the device is damaged. Do not operate the device if you notice any damage. In this case, clean and disinfect the device and send it to ATMOS for repair.
- Perform a function check at least once a week, and also at any other time if you have any concerns with regard to the safety of the device.
- Observe the specifications regarding periodic tests in chapter "7.1 Periodic tests" on page 25.
- Do not modify the device without the manufacturer's permission.
- Only use original accessories and original spare parts from ATMOS.
- Assembly, new settings, modifications, extensions, and repairs may only be carried out by persons who are authorized by ATMOS.

## **2.3 Avoiding damage to the device**

### **Storage and operation in an unsuitable environment.**

Risk of damage to the product.

- Please observe the ambient conditions regarding transport, storage, and operation.

## 3 Setting up and starting up

### 3.1 Device overview

#### Front view

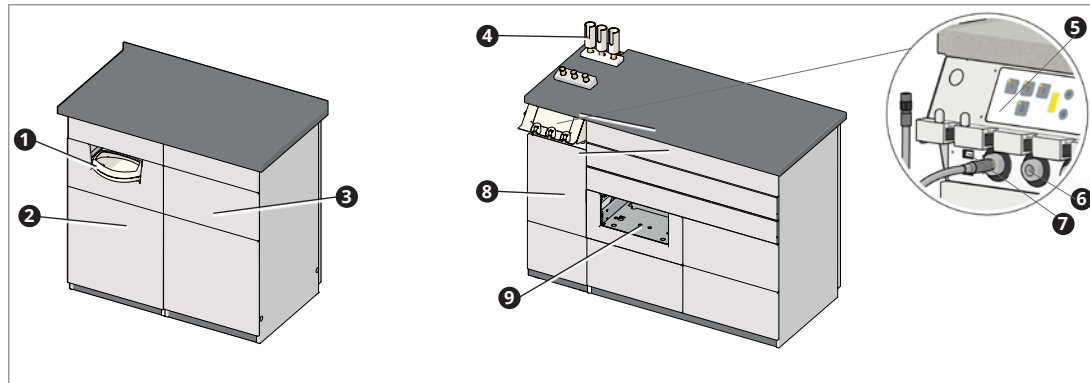

- ❶ Instrument disposal (optional)
- ❷ Waste disposal (optional)
- ❸ Drawer
- ❹ Endoscope holder (optional)
- ❺ ATMOS LED Light Cube CORIAN® control panel (optional)
- ❻ Light source output (optional)
- ❼ USB connections (optional)
- ❽ Storage space for ATMOS devices (optional)
- ❾ Drawer for devices (optional)

#### ATMOS LED Light Cube CORIAN® control panel (optional)

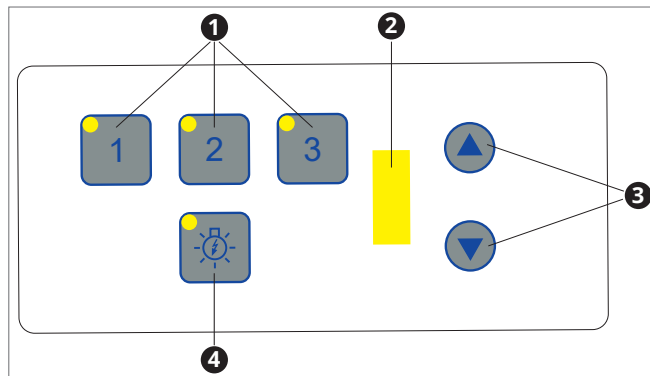

- ❶ Select light source
- ❷ Brightness display
- ❸ Brightness control
- ❹ Stroboscopy mode

### 3.2 Preparing the device

1. Arrange for an authorized ATMOS service partner to connect the device.
2. Perform a function check; see chapter "7.2 Function check" on page 25.
3. Before using the product for the first time, reprocess it according to the operating instructions.

## 4 Operation

### 4.1 Ambient conditions during operation

- Temperature: +10 to +35 °C
- Relative humidity: 30 to 95 % without condensation
- Air pressure: 700...1060 hPa

### 4.2 Switching on the device (ATMOS S 61 CORIAN® integral)

1. Press the ON/OFF button on the ATMOS S 61 Servant ENT workstation. Observe the corresponding operating instructions.
  - » The ATMOS S 61 CORIAN® integral is now switched on.
2. If necessary, switch on the devices stored in the ATMOS S 61 CORIAN® integral. Observe the corresponding operating instructions.

### 4.3 Switching off the device (ATMOS S 61 CORIAN® integral)

1. Press the ON/OFF button on the ATMOS S 61 Servant ENT workstation. Observe the corresponding operating instructions.
  - » The ATMOS S 61 CORIAN® integral is now switched off.
2. If necessary, switch off the devices stored in the ATMOS S 61 CORIAN® integral. Observe the corresponding operating instructions.

### 4.4 Using the drawers

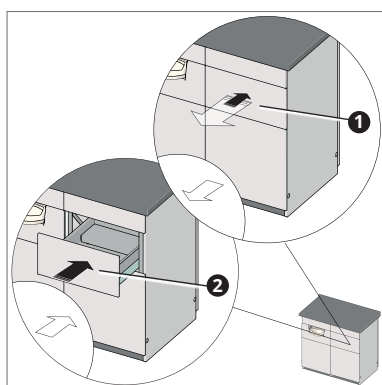

#### Opening the drawers

1. Press against the drawer ❶.
- » The drawer will open.

#### Closing a drawer without Servo-Drive® (only drawer for devices)

1. Push the drawer ❷ in until it clicks closed.

#### Closing a drawer with Servo-Drive®

1. Push the drawer ❷ closed until it is pulled in automatically.

## 4.5 Using the drawer for devices (optional)

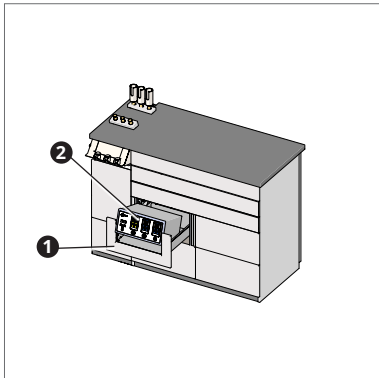

### Inserting a device

1. Press against the drawer for devices **1**.  
» The drawer for devices will open.
2. Insert the device **2**.
3. Close the drawer for devices **1**.

### Removing a device

1. Press against the drawer for devices **1**.  
» The drawer for devices will open.
2. Disconnect all the power cables from the device **2**.
3. Remove the device **2** by lifting it upwards.
4. Close the drawer for devices **1**.

## 4.6 Inserting and removing the instrument disposal tray (optional)

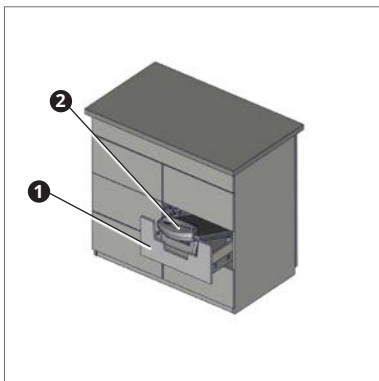

### Inserting the instrument disposal tray

1. Press against the instrument disposal **1**.  
» The instrument disposal will open.
2. Insert the instrument disposal tray with lid **2**.
3. Close the instrument disposal **1**.

### Removing the instrument disposal tray

1. Press against the instrument disposal **1**.  
» The instrument disposal will open.
2. Remove the instrument disposal tray with lid **2** by lifting it upwards.
3. Close the instrument disposal **1**.

## 4.7 Using the waste disposal (optional)

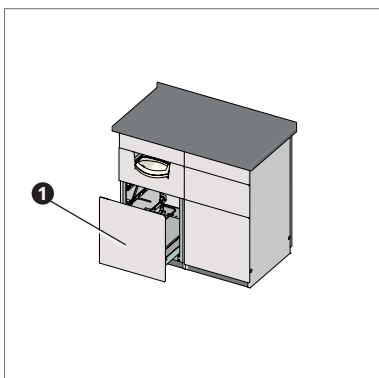

1. Press against the waste disposal **1**.  
» The waste disposal will open.
2. Attach a bin liner.
3. Close the waste disposal **1**.

## 4.8 Using light sources (optional)

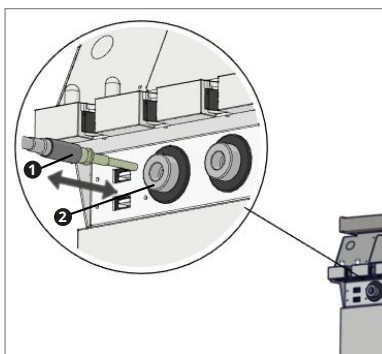

### 4.8.1 Connecting the fiber optic light cable

1. Insert the fiber optic light cable **1** into the LED Light Cube adapter **2** until it clicks gently into place.

### 4.8.2 Removing the fiber optic light cable

1. Pull the fiber optic light cable **1** out of the LED Light Cube adapter **2**.

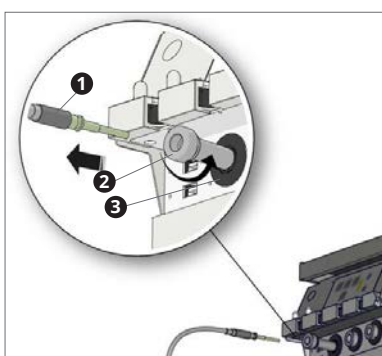

### 4.8.3 Changing the adapter

1. Pull the fiber optic light cable **1** out of the LED Light Cube adapter **2**.
  2. Turn the LED Light Cube adapter **2** counterclockwise to unscrew it from the light source output **3**.
  3. Turn the desired LED Light Cube adapter **2** clockwise to screw it into the light source output **3**.
  4. Insert the matching fiber optic light cable **1** into the LED Light Cube adapter **2** until it clicks gently into place.
- ☞ Perform a function check; see chapter "7.2 Function check" on page 25.

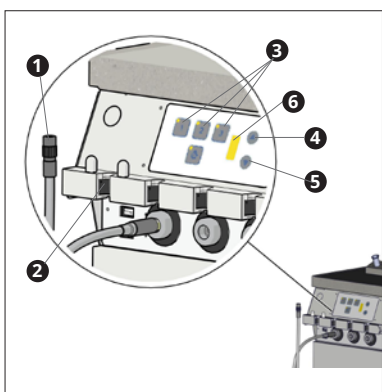

### 4.8.4 Switching on the light source

1. Take the fiber optic light cable **1** out of the fiber optic light cable holder **2**.
- » The LED on the corresponding button will light up **3**.
- ☞ You can use buttons 1 to 3 **3** to switch the light source on manually.

### 4.8.5 Adjusting brightness

1. Switch on the light source.
  2. Press the UP **4** button to increase the brightness or the DOWN **5** button to reduce the brightness.
  3. Display of the brightness **6** of the light source
- ☞ The last setting is retained when the device is switched off.

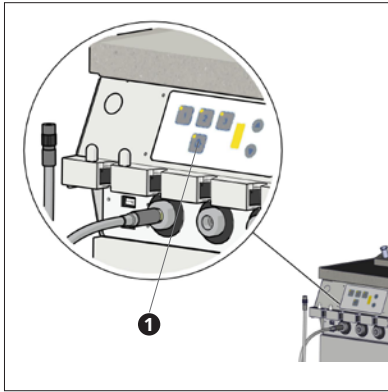

#### 4.8.6 Stroboscopy capability of the light source (optional)

If you have integrated an ATMOS Strobo 21 LED in the storage space for ATMOS visualization devices, stroboscopy is possible with one of the three light sources of the ATMOS LED Light Cube. To do this, proceed as follows:

1. Select a light source as described in chapter 4.8.4 "Switching on the light source."
2. Press the button for strobo mode **1** to turn on the strobo capability for the selected light source. If the strobo mode is active, a green LED lights up next to the button for strobo mode.
  - ☞ If the LED lights up red, no trigger signal is present. The ATMOS Strobo 21 LED is switched off or no ATMOS Strobo 21 LED is connected.
  - ☞ If the LED does not light up, the ATMOS LED Light Cube is ready for use. Use as described in chapter 4.8.6 "Stroboscopy capability of the light source (optional)."
  - ☞ When the device is switched off, the strobo mode setting is retained.
  - ☞ The brightness setting as described in chapter 4.8.5 "Adjusting brightness" does not apply to the brightness setting for strobo capability.
  - ☞ The brightness setting for strobo mode is made via the ATMOS Strobo 21 LED. Observe the operating instructions for the ATMOS Strobo 21 LED.
  - ☞ The display of the brightness also applies here, as described in point 3 of chapter 4.8.5 "Adjusting brightness."



## 4.9 Storing endoscopes (optional)

### **⚠ WARNING**

#### **Risk of infection from contaminated endoscopes.**

Risk of diseases being transmitted.

- Only use the endoscope quivers to store reprocessed endoscopes.
- Do not set contaminated endoscopes down in areas other than those specifically designated for this purpose.

### **⚠ CAUTION**

#### **Risk of burns from heated endoscopes.**

Risk of minor burns.

- Check the temperature of the endoscope before using it on the patient. To do this, hold the endoscope against the back of your hand. Wear gloves to ensure that you do not contaminate the endoscope.

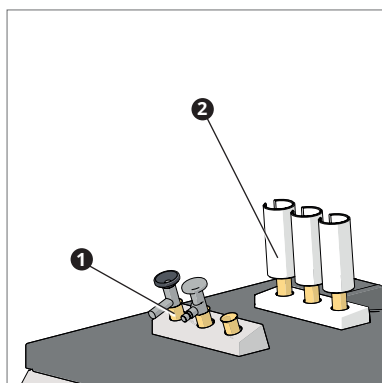

- ① Rigid endoscopes (optionally heated)
- ② Flexible endoscopes

☞ If your product comes with heated endoscope quivers, these will be heated for as long as the ATMOS S 61 Servant ENT workstation remains switched on. After approx. 15 minutes, the endoscopes will reach a temperature of approx. 40 °C.

## 5 Cleaning and disinfection

We recommend that you always document all maintenance work and part replacements in writing.

It is the responsibility of the user to ensure that the required results for cleaning and disinfection are adhered to. Validation and routine monitoring of the procedure will generally be necessary.

### **⚠ WARNING**

#### **Risk of infection due to germs on equipment and accessories.**

Risk of diseases being transmitted.

- Wear disposable gloves during all cleaning and disinfection measures.
- If the CORIAN® surface is scratched or contaminated with difficult-to-remove soiling, please contact ATMOS.
- Clean and disinfect the product according to the operating instructions.

### 5.1 Reprocessing the product

#### 5.1.1 Reprocessing the endoscope quivers

Reprocess endoscope quivers daily.

1. Dismantle the endoscope quiver:
  - Quiver sleeve
  - Sealing ring
  - Quiver stopper
  - Endoscope quiver adapter (optional)
2. Clean the individual parts using a brush.
3. Rinse the individual parts under running water.
4. Clean and disinfect the individual parts manually or mechanically using a suitable instrument disinfectant; see chapter "5.2.2 Instrument disinfectants" on page 21.
  - Manual procedure: immersion disinfection; rinse thoroughly afterwards
  - Mechanical procedure: 93 °C

#### 5.1.2 Reprocessing the instrument disposal trays

Reprocess instrument disposal trays with lid daily.

1. Dismantle the instrument disposal tray:
  - Instrument disposal tray
  - Lid for instrument disposal tray
2. Clean the instrument disposal tray using a brush.
3. Clean and disinfect the individual parts manually using a suitable instrument disinfectant; see chapter "5.2.2 Instrument disinfectants" on page 21.

### 5.1.3 Reprocessing the instrument trays

Reprocess instrument trays daily.

1. Thoroughly rinse the instrument tray under running water.
2. Clean all the surfaces with a damp, clean, lint-free cloth and a cleaning agent.
3. Disinfect the surfaces with a clean, lint-free cloth and a suitable instrument disinfectant; see chapter "5.2.2 Instrument disinfectants" on page 21.

### 5.1.4 Reprocessing the fiber optic light cables

1. Clean and disinfect the fiber optic light cables in accordance with the corresponding operating instructions provided by the manufacturer of the fiber optic light cable.

### 5.1.5 Reprocessing the surfaces

**NOTICE**

#### Liquids in the light source output.

Damaged lens.

- Make sure that no liquids penetrate the light source output.

Material	Surface
CORIAN®	Worktop Endoscope holder Drawer, front Drawer for devices, front Side panel Base
Metal sheet, coated	Drawer, inside Rear side
Other	ATMOS LED Light Cube CORIAN®

1. Switch off the device.
2. Remove all the accessories.
3. Clean all the surfaces with a damp, clean, lint-free cloth and a cleaning agent.
4. Disinfect the surfaces with a clean, lint-free cloth and a suitable surface disinfectant; see chapter "5.2.1 Surface disinfectants" on page 20.
5. Attach the reprocessed accessories.
6. Perform a function check; see chapter "7.2 Function check" on page 25.

## 5.2 Recommended disinfectants

### NOTICE

#### Unsuitable disinfectants.

Risk of damage to the surface, corrosion damage, and stress cracks.

- Only use disinfectants recommended by ATMOS.
- Do not use process chemicals that contain any of the following ingredients on CORIAN® surfaces:
  - Strong acids (e.g., concentrated sulphuric acid)
  - Ketones (e.g., acetone)
  - Chloric solvents (e.g., chloroform)
  - Strong solvent mixtures (e.g., paint remover)

### 5.2.1 Surface disinfectants

#### CORIAN®

Disinfectant	Ingredients	In 100 g	Manufacturer
terralin® protect (Application concentrate)	Benzyl-C12-16 alkyl dimethyl-, chloride 2-phenoxyethanol aminoalkylglycine Non-ionic surfactants, perfumes	22 g 17 g 0.9 g	Schülke & Mayr, Norderstedt

Other suitable active ingredients:

- Ortho-phthalaldehyde
- Glutaraldehyde
- Glutaraldehyde and phenol
- Hydrogen peroxide
- Hydrogen peroxide and peracetic acid
- Peracetic acid
- Phenol
- Sodium hypochlorite
- Quaternary ammonium compounds

#### Coated surfaces

Disinfectant	Ingredients	In 100 g	Manufacturer
Green & Clean SK	Di alkyl dimethyl ammonium chloride Alkyl dimethyl ethyl benzyl ammonium chloride Alkyl dimethyl benzyl ammonium chloride	< 1 g < 1 g < 1 g	Metasys, Rum (Austria)
Dismozon® plus (Granulate)	Magnesium monoperoxyphthalate hexahydrate	95.8 g	Bode Chemie, Hamburg
Kohrsolin® FF (Application concentrate)	Glutaral Benzyl-C12-C18-alkyl dimethyl-ammonium chloride Didecyl dimethyl ammonium chloride	5 g 3 g 3 g	Bode Chemie, Hamburg
Perform®	Pentapotassium-bis(peroxy monosulphate)-bis(sulphate)	45 g	Schülke & Mayr, Norderstedt

Disinfectant	Ingredients	In 100 g	Manufacturer
terralin® protect (Application concentrate)	Benzyl-C12-16 alkyldimethyl-, chloride 2-phenoxyethanol Aminoalkylglycine Non-ionic surfactants, perfumes	22 g 17 g 0.9 g	Schülke & Mayr, Norderstedt

## Other surfaces

Disinfectant	Ingredients	In 100 g	Manufacturer
Green & Clean SK	Di alkyl dimethyl ammonium chloride Alkyl dimethyl ethyl benzyl ammonium chloride Alkyl dimethyl benzyl ammonium chloride	< 1 g < 1 g < 1 g	Metasys, Rum (Austria)
Dismozon® plus (Granulate)	Magnesium monoperoxyphthalate hexahydrate	95.8 g	Bode Chemie, Hamburg
Incidin® Plus (Application concentrate)	Glucoprotamin	26 g	Ecolab, Düsseldorf

## 5.2.2 Instrument disinfectants

### Manual disinfection of instruments

Disinfectant	Ingredients	In 100 g	Manufacturer
Korsolex® med AF (Application concentrate)	N-dodecylpropane-1,3-diamine N-(3-aminopropyl)-N-dodecylpropane-1,3-diamine Surfactants, corrosion inhibitors, pH-value regulators, foam inhibitors	15.6 g 5.1 g	Bode Chemie, Hamburg
Korsolex® basic (Application concentrate)	Glutaral (ethylenedioxy)dimethanol Surfactants, salts, corrosion inhibitors	15.2 g 19.7 g	Bode Chemie, Hamburg
Korsolex® plus (Application concentrate)	N-(3-aminopropyl)-N-dodecylpropane-1,3-diamine Didecyldimethylammonium chloride Surfactants, corrosion inhibitors, complexing agents, pH-value regulators	9.2 g 13.0 g	Bode Chemie, Hamburg
Korsolex® extra (Application concentrate)	(ethylenedioxy)dimethanol Glutaral Benzyl-C12-18-alkyldimethyl-ammonium chlorides Didecyldimethylammonium chloride Surfactants, foam inhibitors, corrosion inhibitors	15.3 g 7.5 g 1.0 g 1.0 g	Bode Chemie, Hamburg
neodisher® Septo MED (Application concentrate)	N-(3-aminopropyl)-N-dodecylpropane-1,3-diamine Didecyldimethylammonium chloride Non-ionic surfactants, perfumes	9.2 g 13.0 g	Dr. Weigert, Hamburg
neodisher® Septo 3000 (Application concentrate)	Glutaral (ethylenedioxy)dimethanol	15.2 g 19.7 g	Dr. Weigert, Hamburg
Sekusept® PLUS (Application concentrate)	Glucoprotamin	25 g	Ecolab, Düsseldorf

Disinfectant	Ingredients	In 100 g	Manufacturer
Sekusept® aktiv (Application concentrate)	Sodiumpercarbonate, non-ionic surfactants, phosphonates		Ecolab, Düsseldorf
gigasept® instru AF (Application concentrate)	Cocospropylendiaminguanidindiacetate Phenoxypropanols Benzalkonium chloride Non-ionic surfactants, pH-value regulators, corrosion inhibitors	14 g 35 g 2.5 g	Schülke & Mayr, Norderstedt
gigasept® FF (new) (Application concentrate)	Succindialdehyde dimethoxytetrahydrofurane Anionic and non-ionic surfactants, perfumes, methylisothiazolinone	11.9 g 3.2 g	Schülke & Mayr, Norderstedt
Gigazyme® (Application concentrate)	Non-ionic surfactants enzymes, corrosion inhibitors	5–15 g	Schülke & Mayr, Norderstedt

### Mechanical disinfection of instruments























Disinfectant	Ingredients	In 100 g	Manufacturer
Dismoclean® 24 Vario (Application concentrate)	Surfactants, micro-encapsulated enzymes, corrosion inhibitors, complexing agents		Bode Chemie, Hamburg
Dismoclean® 28 alka med (Application concentrate)	Alkali dispenser, complexing agents, corrosion inhibitors, surface active materials		Bode Chemie, Hamburg
Dismoclean® twin basic	Alkali dispenser, complexing agents, corrosion inhibitors		Bode Chemie, Hamburg
Dismoclean® twin zyme	Surface active materials, enzymes, stabilisers, corrosion inhibitors		Bode Chemie, Hamburg
neodisher® FA	Phosphates	15 - 30 g	Dr. Weigert, Hamburg
neodisher® MediClean forte (Application concentrate)	Non-ionic and anionic surfactants Enzymes	< 5 g	Dr. Weigert, Hamburg
Thermosept® alka clean forte (Application concentrate)	Non-ionic surfactants Anionic surfactants NTA (nitrilotriacetic acid) and its salts Polycarboxylates Enzymes, corrosion inhibitors	< 5 g < 5 g < 5 g < 5 g	Schülke & Mayr, Norderstedt
Thermosept® RKN-zym	Non-ionic surfactants Enzymes, corrosion inhibitors, glycols	5–15 g	Schülke & Mayr, Norderstedt

# 6 Hygiene plan



## Cleaning and disinfection plan ATMOS S 61 CORIAN®



	What	How			Notes	When			Who
		C Cleaning	D Disinfection	S Sterilization		After each application	Daily	Weekly	
<b>Secretion canister</b>									
	Hose connection (grommet)	X	X <sup>2,4,5</sup>		Cleaning and disinfection (mechanical or manual)		X		
	Secretion canister lid	X	X <sup>2,4,5</sup>		Cleaning and disinfection (mechanical or manual)		X		
	Sealing	X	X <sup>2,4,5</sup>		Cleaning and disinfection (mechanical or manual)		X		
	Bacterial filter				Exchange daily or when blocked		X		
	Splash guard	X	X <sup>2,4,5</sup>		Cleaning and disinfection (mechanical or manual)		X		
	Float ball	X	X		Cleaning and disinfection (mechanical or manual)		X		
	Suction hose in the canister	X	X <sup>2,4,5</sup>		Cleaning and disinfection (mechanical or manual)		X		
	Secretion canister	X	X		Empty when the canister is full; at least daily; Cleaning and disinfection (mechanical or manual)		X		
	Disposable canister system				Exchange and disposal of full canister		X		
<b>Hose rinsing system</b>									
	Suction nozzle for hose rinsing	X	X <sup>3</sup>		Wipe cleaning and disinfection		X		
	Silicone attachment piece	X	X <sup>2,4,5,6</sup>		Cleaning and disinfection (mechanical or manual)		X		
	Suction nipple	X			Exchange of the silicone attachment				X
	Secretion suction hose	X	X <sup>2,4,5,6</sup>		Manual cleaning after each application		X		
	Storage canister hose rinsing	X	X <sup>2,4,5,6</sup>		Cleaning and disinfection (mechanical or manual)		X		
	Secretion suction hose	X			Rinse the secretion suction hose with the hose rinsing system after each application		X		
	Secretion suction hose		X <sup>2,4,5,6</sup>		Exchange or disinfection of the hose				X
	Storage canister hose rinsing	X	X <sup>2,4,5,6</sup>		Cleaning with a brush; cleaning and disinfection (mechanical or manual)		X		
<b>Ear irrigation / Thermal nystagmus stimulation</b>									
	Ear irrigation bowl	X	X <sup>2,4,5</sup>		Cleaning and disinfection (mechanical or manual)		X		
	Handle	X	X <sup>3</sup>		Wipe cleaning and disinfection		X		
	Jet connection	X	X <sup>2,4,5,6</sup>		Cleaning and disinfection (mechanical or manual)		X		
	Splash protection	X	X <sup>2,4,5</sup>		Cleaning and disinfection (mechanical or manual)		X		
	Hose tip (disposable)				Exchange after each application		X		
	Rinsing attachment	X	X <sup>2,4,5</sup>		Cleaning and disinfection (mechanical or manual)		X		
	Hygiene filter				See operating instructions for hygiene filter				X
	Rinsing lid with rinsing hose	X	X <sup>2,4,5</sup>		Cleaning and disinfection (mechanical or manual)		X		
	Rinsing bottle	X	X <sup>2,4,5,6</sup>		Cleaning and disinfection (mechanical or manual); cleaning in the dishwasher with the glass care program		X		
<b>Medication sprayer / Politzer olive</b>									
	Handle compressed air	X	X <sup>3</sup>		Manual cleaning and disinfection		X		
	Jet connection	X			Cleaning after each application		X		
	Sprayer head		X <sup>2,4,5,6</sup>		See operating instructions medication sprayer				
	Hose on sprayer head		X <sup>2,4,5,6</sup>		Cleaning and disinfection (mechanical or manual)		X		
	Sprayer bottle	X	X		Multiple rinsing of the sprayer head with water			X	
	Hose on sprayer head	X	X		Weekly exchange of the hose or when changing the medication			X	
	Sprayer bottle	X	X <sup>2,4,5,6</sup>		Cleaning in a cleaning and disinfection device; weekly or when changing the medication			X	
	Pulitzer olive	X	X <sup>2,4,5,6</sup>		Exchange after each application; then cleaning and disinfection		X		
	Pulitzer olive adapter	X	X <sup>2,4,5,6</sup>		Exchange after each application; then cleaning and disinfection		X		
<b>Endoscope management</b>									
	Metal quiver	X	X <sup>2,4,5,6</sup>		Cleaning with a brush; then disinfection (mechanical or manual)		X		
	Fixation adapter for plastic quiver	X	X <sup>2,4,5</sup>		Cleaning and disinfection (mechanical or manual)		X		
	Protective sleeve (teflon element for metal quiver)	X	X <sup>2,4,5</sup>		Cleaning and disinfection (mechanical or manual)		X		

	What	How			Notes	When				Who
		C Cleaning	D Disinfection	S Sterilization		After each application	Daily	Weekly	Monthly	
<b>Instrument management</b>										
	Instrument bowl	X	X <sup>4</sup>		Cleaning and disinfection (manual)		X			
	Instrument disposal bowl with cover	X	X <sup>4</sup>		Cleaning with a brush; disinfection (manual)		X			
<b>Visualization</b>										
	ATMOS iQam	X	X <sup>1,4</sup>		Wipe cleaning and disinfection See operating instructions ATMOS iQam	X				
	ATMOS Strobo 21 LED	X	X <sup>3</sup>		Wipe cleaning and disinfection		X			
	ATMOS LS 21 LED	X	X <sup>3</sup>		Wipe cleaning and disinfection		X			
	Flexible endoscope	X	X <sup>1</sup>	X <sup>1</sup>	Immediate precleaning after application See the manufacturer's operating instructions!	X				
	Rigid endoscope	X	X <sup>1</sup>		See the manufacturer's operating instructions!	X				
	Laryngoscope	X	X <sup>1</sup>	X <sup>1</sup>	Immediate precleaning after application See the manufacturer's operating instructions!	X				
	Fiber optic light cable	X	X <sup>3</sup>		Wipe cleaning and disinfection		X			
	Transformer	X	X <sup>1</sup>		Wipe cleaning and disinfection		X			
	Microscope	X	X <sup>3</sup>		Wipe cleaning and disinfection		X			
	Headlight	X	X <sup>3</sup>		Wipe cleaning and disinfection		X			
<b>Radiofrequency surgery</b>										
	ATMOS RS 221 (device surface)	X	X <sup>3</sup>		Wipe cleaning and disinfection		X			
	Ergonomic handles	X	X <sup>1,2,4,5</sup>	X <sup>1</sup>	Wipe cleaning and disinfection	X				
	Bipolar tweezers	X	X <sup>1,2,4,5</sup>	X <sup>1</sup>	Immediate precleaning after application; Cleaning and disinfection (mechanical or manual); Use of enzymatic detergents	X				
	Bipolar electrode	X	X <sup>1,2,4,5</sup>	X <sup>1</sup>	Immediate precleaning after application; Cleaning and disinfection (mechanical or manual); Use of enzymatic detergents	X				
	Bipolar electrode cable	X	X <sup>1,2,4,5</sup>	X <sup>1</sup>	Immediate precleaning after application; Cleaning and disinfection (mechanical or manual); Use of enzymatic detergents	X				
	Neutral electrode	X	X <sup>1,2,4,5</sup>	X <sup>1</sup>	Immediate precleaning after application; Cleaning and disinfection (mechanical or manual); Use of enzymatic detergents	X				
	Neutral electrode cable	X	X <sup>1,2,4,5</sup>	X <sup>1</sup>	Immediate precleaning after application; Cleaning and disinfection (mechanical or manual); Use of enzymatic detergents	X				
	ENT electrodes	X	X <sup>1,2,4,5</sup>	X <sup>1</sup>	Immediate precleaning after application; Cleaning and disinfection (mechanical or manual); Use of enzymatic detergents	X				
<b>Surfaces</b>										
	Housing CORIAN®	X	X <sup>3</sup>		Wipe cleaning and disinfection		X			
	Coated housing	X	X <sup>3</sup>		Wipe cleaning and disinfection		X			
	Drawers	X	X <sup>3</sup>		Wipe cleaning and disinfection			X		
	Mirror preheater	X	X <sup>3</sup>		Wipe cleaning and disinfection			X		
	Tongue patches and swab dispenser	X	X <sup>3</sup>		Wipe cleaning and disinfection; Daily or when refilling		X			
	Waste disposal	X	X <sup>3</sup>		Wipe cleaning and disinfection; Daily or when refilling		X			
	Instrument tray	X	X <sup>3</sup>		Wipe cleaning and disinfection; Daily or when refilling		X			

### Recommended disinfectants

- <sup>1)</sup> Surface disinfection for CORIAN®:
- Terralin® Protect (Schülke & Mayr)
- <sup>2)</sup> Surface disinfection for coated surfaces:
- Green & Clean SK (ATMOS)
  - Dismozon® plus (Bode Chemie)
  - Kohrsolin® FF (Bode Chemie)
  - Perform® (Schülke & Mayr)
  - Terralin® Protect (Schülke & Mayr)
- Other surfaces:
- Dismozon® plus (Bode Chemie)
  - Kohrsolin® FF (Bode Chemie)
  - Mikrobac® forte (Bode Chemie)
  - Perform® (Schülke & Mayr)
  - Terralin® Protect (Schülke & Mayr)
  - Surface disinfectant FD 312 (Dürr Dental)
  - Green & Clean SK (ATMOS)
  - Dismozon® plus (Bode Chemie)
  - Incidin® Plus (Application concentrate)

- <sup>4)</sup> Manual disinfection of instruments:
- Korsolex® med AF (Bode Chemie)
  - Korsolex® basic (Bode Chemie)
  - Korsolex® plus (Bode Chemie)
  - Korsolex® extra (Bode Chemie)
  - neodisher® Septo MED (Dr. Weigert)
  - neodisher® Septo 3000 (Dr. Weigert)
  - Sekusept® PLUS (Ecolab)
  - Sekusept® aktiv (Ecolab)
  - gigasept® instru AF (Schülke & Mayr GmbH)
  - gigazyme® (Schülke & Mayr)
  - gigasept® FF (new) (Schülke & Mayr GmbH)
- <sup>5)</sup> Mechanical disinfection of instruments:
- Dismoclean® 24 Vario (Bode Chemie)
  - Dismoclean® 28 alka med (Bode Chemie)
  - Dismoclean® twin basic/twin zyme (Bode Chemie)
  - neodisher® FA (Dr. Weigert)
  - neodisher® MediClean forte (Dr. Weigert)
  - thermosept® alka clean forte (Schülke & Mayr)
  - thermosept® RKN-zym (Schülke & Mayr)

- <sup>7)</sup> Endoscopes – manual disinfection:
- Heliapur® H plus N (BBraun)
  - Helix® Ultra (BBraun)
  - Korsolex® basic (Bode Chemie)
  - neodisher® MediClean forte (Dr. Weigert)
  - Sekusept® aktiv (Ecolab)
- <sup>8)</sup> Endoscopes – mechanical disinfection:
- Korsolex® basic (Bode Chemie)
  - neodisher® MediClean forte (Dr. Weigert)
  - gigasept® FF new (Schülke & Mayr)
  - Endozime® AW Plus (Ruhof)
  - ADAPTACLEAN™ (ASP)

For concentrations, contact time, temperature and material compatibility, please see the relevant information from the manufacturer.

This hygiene plan was created on the basis of the Medical Device Regulation (MDR), the German Medical Devices Operator Ordinance (MPBetreibV), §18 of the German Protection against Infection Act (IfSG), the recommendations made by the Robert Koch Institute, and the currently valid standards and recommendations of professional associations.

The required reprocessing steps were defined on the basis of standard DIN EN ISO 17664:2018-04 and the recommendations "Requirements for the reprocessing of medical devices" from the Robert Koch Institute. The medical devices were also categorized into the risk groups uncritical, semi-critical, and critical.

The disinfectants recommended in this hygiene plan are listed disinfectants (VAH/RKI list) and have been tested for material compatibility for this device.

ATMOS MedizinTechnik cannot be held liable for any damage to materials caused by using wrong concentrations of the disinfectants or by using non-recommended disinfectants.

For further information, please read the operating instructions, which provide additional information about this device and its accessories.

### Important information

Wipe cleaning and disinfection:  
All surfaces must be wiped with a clean (disposable) wipe that is dampened with disinfectant solution. The entire surface must be wiped thoroughly and may not be dried afterwards.

- <sup>1)</sup> Please observe the manufacturer's operating instructions.
- <sup>2)</sup> Preferred; mechanical cleaning and disinfection in a washer-disinfector
- <sup>6)</sup> Material dimensionally stable at 134 °C

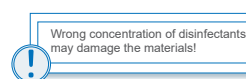

ATMOS MedizinTechnik GmbH & Co. KG  
Ludwig-Kegele-Str. 16 ■ 79853 Lenzkirch/Germany  
Phone +49 7653 689-0 ■ Fax +49 7653 689-190  
info@atmosmed.com ■ www.atmosmed.com



## 7 Maintenance and service

Maintenance, repairs, and periodic tests may only be carried out by persons who have the appropriate technical knowledge and are familiar with the product. The person in question must possess the necessary test devices and original spare parts required to carry out these measures.

ATMOS recommends: Work should be carried out by an authorized ATMOS service partner. This ensures that repairs and testing are carried out professionally, original spare parts are used, and warranty claims remain unaffected.

Maintenance, repairs, and periodic tests may **not** be carried out while the product is being used on the patient.

### 7.1 Periodic tests

#### ATMOS S 61 CORIAN® instruments / ATMOS S 61 CORIAN® instruments XXL

None

#### ATMOS S 61 CORIAN® integral

Observe the specifications for the individual components.

### 7.2 Function check

Perform a function check at least once a week, and also at any other time if you have any concerns with regard to the safety of the device.

Do not operate the product if you notice any damage. In this case, clean and disinfect the device and send it to ATMOS for repair.

#### All variants

1. Check that the product is not damaged.
2. Check that the product is in good hygienic condition.
3. Check that all the moving parts can be adjusted without any problems:
  - Drawer
  - Drawer for devices
  - Waste disposal
  - Deposit for used instruments

#### ATMOS S 61 CORIAN® integral

1. Check whether the LED Light Cube adapters are connected correctly.
2. Connect the fiber optic light cables or check whether the fiber optic light cables are connected properly.
3. Switch on the device and check whether all the LEDs on the ATMOS LED Light Cube CORIAN® control panel light up.
4. Point each fiber optic light cable at a white surface and check whether the light source lights up.

### 7.3 Sending in the device

1. Remove all consumables and dispose of them properly.
2. Clean and disinfect the product and accessories in accordance with the operating instructions.
3. Place any used accessories with the product.
4. Fill in the QD 434 "Delivery complaint/return shipment" form and the corresponding **decontamination certificate**.
- ☞ This form is enclosed with each delivery and can be found at [www.atmosmed.com](http://www.atmosmed.com).
5. The device must be well padded and packed in suitable packaging.
6. Place the QD 434 "Delivery complaint/return shipment" form and the corresponding **decontamination certificate** in an envelope.
7. Affix the envelope to the outside of the package.
8. Send the product in to ATMOS or your dealer.

## 8 Troubleshooting

The product has been subjected to a thorough quality control in the factory. If a fault should occur despite this care, you may be able to resolve it yourself.

### ATMOS LED Light Cube CORIAN®

Error symptom	Possible cause	Remedy
No light	Device is not switched on.	1. Switch on the device.
	Defective power cable.	1. Observe the operating instructions for the ATMOS S 61 Servant ENT workstation.
	Defective fuse.	
Insufficient light.	LED Light Cube adapter not attached correctly.	1. Check whether the fiber optic light cable adapter is fitted properly.
	LED Light Cube adapter not suitable for the fiber optic light cable.	1. Use an LED Light Cube adapter that is suitable for the fiber optic light cable.
	Fiber optic light cable defective.	1. Replace the fiber optic light cable.
Light is too bright/ dark.	Brightness not adjusted.	1. Adjust the brightness.

### Servo-Drive®

Observe the corresponding operating instructions.

## 9 Accessories

Accessories	REF
Stand (ATMOS S 61 Servant)	534.0119.0
Slanted microscope column	534.0170.0
Monitor arm ATMOS S 61 ENT professional	534.3020.0
Monitor holder (shelf adapter / ATMOS S 61 system)	534.3095.0
Shelf for storage device	538.2120.0
Shelf, small (metal)	541.1600.0
Shelf, broad (metal)	541.2700.0
Instrument tray, small (melamine)	000.0746.0
Instrument tray, small (aluminium)	508.0058.0
Fixation adapter plastic quiver	508.0782.0
Instrument disposal bowl	506.7751.0
Cover for instrument disposal bowl	506.7752.0
Stainless steel sieve (instrument disposal)	506.7759.0
Roller cover (Second instrument level)	506.7730.0
Instrument tray, large (aluminium)	505.0516.0
Tray, narrow	532.0146.0
Tray, narrow (instrument deposit)	534.0146.0
Holder ear specula / Politzer olives	508.0545.0
Instrument tray, large (melamine)	000.0747.0
Tray for melamine trays, narrow	532.0145.0
Tray for melamine trays, narrow (instrument deposit)	534.0145.0
Instrument deposit module	534.3040.0
Instrument deposit module, high	534.3045.0
Shelf (glass)	534.3050.0
Shelf (metal)	534.3060.0
Shelf (glass), high	534.3055.0
Shelf (metal), high	534.3065.0
Shelf adapter	534.3090.0
Quiver, flexible endoscopes	508.0790.0
Push-on sleeve, flex optic sleeve	506.0715.0
Quiver, used flexible endoscopes	508.0795.0
Holder flexible optic incl. Quiver	506.7017.0
Instrument tray set (aluminium)	506.7032.0
Instrument tray set (stainless steel)	506.7033.0

## 10 Disposal

### Packaging

1. Please recycle the packaging.

### Product

Do not dispose of the product together with household waste.

The product does not contain any hazardous materials.

1. Clean and disinfect the device.
2. Dispose of the product professionally and in accordance with country-specific laws and regulations.

The housing is fully recyclable. Nevertheless, always take care to observe country-specific laws and regulations.



## 11 Technical data

### ATMOS S 61 CORIAN® instruments / ATMOS S 61 CORIAN® instruments XXL

Environmental conditions: Transport/Storage	
• Temperature range:	-10...+50°C
• Air humidity without condensation:	30...95 %
• Air pressure:	500...1060 hPa
Environmental conditions: Operation	
• Temperature:	+10...+35°C
• Air humidity without condensation:	30...95 %
• Air pressure:	700...1060 hPa
Dimensions (H x W x D)	Integral                    82 x 115 x 60 cm Instruments                79 x 44 x 50 cm Instruments XXL          79 x 84 x 50 cm
Weight:	Integral                    max. 230 kg Instruments                max. 55 kg Instruments XXL          max. 90 kg
Periodical tests:	Follow the instructions for the individual components.
Degree of protection against Ingress	IP X0
CE mark	<b>CE</b>
Ident-No. (REF)	Integral                    532.0800.0 Instruments                532.1000.0 Instruments XXL          532.0900.0

\* Important: Note on MPBetreibV only for devices that are listed there accordingly!

#### Connection values of the isolating transformer

Mains voltage	230 V~ ± 10 %; 50/60 Hz Special voltage: 115 V~ ± 10 %; 50/60 Hz
Power consumption:	Max. 600 VA
Fuses	T 3,15 A (f. 230 V~, 50/60 Hz) T 6,3 A (f. 110 V~, 127 V~, 50/60 Hz)
Power cycle	Continuous operation

Protective earth conductor resistance	max. 0,1 $\Omega$
Earth leakage current	max. 0,5 mA
Housing leakage current	max. 0,1 mA
Patient leakage current	max. 0,1 mA
Protection class against electric shock (acc. to EN 60601-1)	I
Contamination level	2
Overtoltage category	II

### ATMOS S 61 CORIAN® integral

Mains voltage	230 V~ $\pm$ 10 %; 50/60 Hz special voltage: 100-127 V~ $\pm$ 10 %; 50/60 Hz
Current consumption:	max. 1,1 A (230 V~) max. 2.2 A (100 V~)
Power consumption:	max. 580 W
Other power sources:	no other power sources
Fuses	2 x T 3,15 A H (230 V~, 50/60 Hz) 2 x T 3,15 A H (100 - 127 V~, 50/60 Hz)
Other security parts:	Heating elements depending on design max 60 °C
Heated drawer <ul style="list-style-type: none"> <li>• Temperature on instruments</li> <li>• Heating performance</li> </ul>	approx. 37 °C max. 250 VA
Power cycle	Continuous operation
Protective earth conductor resistance	max. 0,1 $\Omega$
Earth leakage current	max. 0,5 mA
Touch current	max. 0,1 mA
Patient leakage current	max. 0,1 mA
Environmental conditions: Transport/Storage <ul style="list-style-type: none"> <li>• Temperature range:</li> <li>• Air humidity without condensation:</li> <li>• Air pressure:</li> </ul>	+10...+50°C 30...95 % 500...1060 hPa
Environmental conditions: Operation: <ul style="list-style-type: none"> <li>• Temperature range:</li> <li>• Air humidity without condensation:</li> <li>• Air pressure:</li> </ul>	+10...+35°C 30...95 % 700...1060 hPa
Maximum operating altitude	3000 m (NN)
Contamination level	Class 2

Overvoltage category	II
Dimensions (H x W x D):	82 x 115 x 60 cm
Weight:	max. 230 kg
Periodical tests:	Repeat test of the electrical safety every 12/ 24 months. Recommended: inspection according to manufacturer's specifications.
Protection class against electric shock (acc to EN 60601-1)	I
Degree of protection against electric shock	np applied parts
Degree of protection against Ingress	IP X0
CE mark	<b>CE</b>
Ident-No. (REF)	Integral                      532.0800.0

\* Important: Note on MPBetreibV only for devices that are listed there accordingly!

#### Connection values of the isolating transformer

Mains voltage	230 V~ ± 10 %; 50/60 Hz Special voltage: 115 V~± 10 %; 50/60 Hz
Power consumption:	max. 600 VA
Fuses	T 3,15 A (f. 230 V~, 50/60 Hz) T 6,3 A (f. 110 V~, 127 V~, 50/60 Hz)
Power cycle	Continuous operation
Protective earth conductor resistance	max. 0,1 Ω
Earth leakage current	max. 0,5 mA
Housing leakage current	max. 0,1 mA
Patient leakage current	max. 0,1 mA
Contamination level	2
Overvoltage category	II
Protection class against electric shock (acc. to EN 60601-1)	I



## 12 Notes on EMC

Medical electrical equipment is subject to special precautions with regard to EMC and must be installed according to the following EMC notes.

### Guidance and manufacturer's declaration – ambient conditions

The ATMOS S 61 CORIAN® integral is suitable for use in the following environments:

- In fields of home health care in any buildings, outdoor areas, and means of transport.
- In professional healthcare facilities such as medical practices, hospitals/clinics, first-aid facilities, and operating theatres/rooms.

The following environments are not suitable:

- Special environments such as factory or military facilities and medical areas near HF surgical devices, short-wave therapy equipment, or within an HF-shielded room of a magnetic resonance imaging system.

The customer or user of the ATMOS S 61 CORIAN® integral must ensure that it is used in a prescribed environment.

### Guidance and manufacturer's declaration – key features

- ☞ Please note the technical data in these instructions. The essential features are fully usable even in the presence of electromagnetic disturbances.

### Guidance and manufacturer's declaration – removable components that can be replaced by the operator

The ATMOS S 61 CORIAN® integral has the following removable components that can be replaced by the operator:

Type	REF	Max. cable length
Power cable	507.0859.0	3.0 m

### Guidance and manufacturer's declaration – warnings

#### **⚠ WARNING**

The use of electrical components and accessories other than those specified or provided by the manufacturer may cause increased electromagnetic interference or reduced immunity to electromagnetic interference and result in faulty operation of the device.

#### **⚠ WARNING**

Portable RF communications equipment (e.g., radios, antenna cables) should be used no closer than 30 cm\* to any part of the ATMOS S 61 CORIAN® integral, including cables, specified by the manufacturer. Otherwise, degradation of the performance of this equipment could result.

- ☞ \*The distance may be reduced at higher immunity test levels.

#### **⚠ WARNING**

Avoid placing the device on top of or next to another device. This could otherwise result in faulty operation. If such placement cannot be avoided, the proper functioning of the device must be monitored regularly. If possible, please switch off any nearby devices that are not in use.



**MedizinTechnik**

 ATMOS MedizinTechnik GmbH & Co. KG

Ludwig-Kegel-Str. 16

79853 Lenzkirch/Germany

Phone: +49 7653 689-0

info@atmosmed.com

[www.atmosmed.com](http://www.atmosmed.com)