

Operating Instructions

ATMOS Record 55

with standard rail

English



Table of contents

1	Introduction.....	4
1.1	Notes on operating instructions	4
1.2	Explanation of pictures and symbols	5
1.3	Intended use.....	7
1.4	Function.....	8
1.5	Intended users	8
1.6	Scope of delivery	8
1.7	Transport and storage	8
2	Notes for your safety.....	9
2.1	General safety instructions.....	9
2.2	Danger for users, patients and third parties	9
2.3	Avoiding damage to the device	11
3	Setting up and starting up	12
3.1	Device overview.....	12
4	Operation.....	13
4.1	Initial start-up	13
4.2	Preparing the device	13
4.3	Connecting the bacterial filter	13
4.4	Attaching the connecting hose.....	13
4.5	Attaching the secretion canister.....	13
4.6	Connecting the suction hose	14
4.7	Serres®, Medi-Vac® secretion canister system, other canister systems	14
4.8	Secretion canister system	14
4.9	Double hose connector	14
4.10	Using an overflow canister.....	15
4.11	Using a smoke evacuation filter	15
4.12	Suction.....	15
4.13	Checking the bacterial filter	16
4.14	Exchanging the secretion canister	16
4.15	Changing Serres®, Medi-Vac® secretion canister system and other secretion canister systems.....	16
4.16	Options.....	17

5	Reprocessing.....	18
5.1	Safety instructions for reprocessing.....	18
5.1.1	General safety instructions.....	18
5.1.2	Danger for users, patients and third parties.....	18
5.1.3	Avoiding damage to the device.....	18
5.2	Preparing/completing reprocessing.....	19
5.3	Reprocessing surfaces.....	19
5.3.1	Overview.....	19
5.3.2	Selecting process chemicals.....	20
5.3.3	Pre-cleaning.....	20
5.3.4	Wipe disinfection.....	20
5.4	Reprocessing the accessories.....	21
5.4.1	Overview.....	21
5.4.2	Selecting process chemicals.....	21
5.4.3	Secretion canister system.....	21
5.4.4	Hoses.....	23
6	Maintenance and service.....	24
6.1	Periodic tests.....	24
6.2	Function check.....	24
6.3	Sending in the device.....	24
6.4	Reprocessing by the manufacturer.....	24
7	Troubleshooting.....	25
7.1	Remedying malfunctions.....	25
8	Accessories.....	26
9	Disposal.....	28
9.1	Expected service life.....	28
10	Technical data.....	29
11	Notes on EMC.....	31

1 Introduction

1.1 Notes on operating instructions



These operating instructions contain important information on how to operate your product safely, correctly, and effectively.

These operating instructions are designed for training and instructing new operating personnel in the use of the system and also for use as a reference manual. This document may be reprinted, either in part or in whole, only with written permission from ATMOS.

These operating instructions must always be kept to hand near the device.



Care, periodic tests, regular cleaning and proper application are essential. They ensure the operational safety and usability of the product.

Maintenance, repairs, and periodic tests may be carried out only by persons who have the appropriate technical knowledge and are familiar with the product. The person in question must possess the necessary test devices and original spare parts required to carry out these measures.



Read chapter '2 Notes for your safety' on page 9 before using the product for the first time. This will help you to avoid potentially dangerous situations.

The product bears the CE marking CE 0124 in accordance with EU Council Directive 93/42/EEC concerning medical devices and meets the basic requirements of Annex I to this directive.

The product complies with all applicable requirements of Directive 2011/65/EU on the restriction of the use of certain hazardous substances in electrical and electronic equipment ('RoHS').

The Declaration of Conformity and our general standard terms and conditions can be viewed on our website at www.atmosmed.com.







The quality management system applied at ATMOS has been certified according to international standard EN ISO 13485.

These operating instructions are valid for the following devices:

ATMOS Record 55 with standard rail – 230 V REF 443.0700.0























1.2 Explanation of pictures and symbols

In the operating instructions

 DANGER	Warning of a danger that will result in immediate fatal or serious injury. Observe the necessary measures.
 WARNING	Warning of a danger that can cause fatal or serious injury. Observe the necessary measures.
 CAUTION	Warning of a danger that can cause minor injury. Observe the necessary measures.
NOTICE	Notice of a danger that can damage the product or other objects. Observe the necessary measures.
	Warning of a danger that can cause fatal or serious injury.
	Useful information on the handling of the device.
1.	Action. Proceed step by step.
»	Result of an action.
	Move, plug in this direction.

On device and type plate

	Follow operating instructions (blue)
	Consult operating instructions
	Warning; pay special attention
	This product complies with the relevant requirements of the EU Directives.
	This product complies with the relevant requirements of the EU Directives.
	Eurasian conformity
	Manufacturer
	Date of manufacture Country of manufacture
	Foot switch
	Reference number

	Unique Device Identifier of a medical device
	Medical device
	Serial number
IPX1	Protection against the ingress of harmful moisture (dripping water)
	Type BF applied part
	Professional disposal
	For single use only (symbol located on consumables)
	Non-sterile
	Autoclavable
	Connection for suction hose / patient (Serres® canister system)
	Potential equalisation
	Protection class II
	Fuse
	Alternating current
	On, connected to the power supply
	Class AP (for use in potentially explosive areas)
	This side up
	Fragile, handle with care
	Keep dry
	Keep away from sunlight
	Temperature limit
	Humidity limitation
	Atmospheric pressure limitation

UDI application identifier

(01)	UDI-DI: Identification of the manufacturer and the device
(10)	Batch code
(11)	Date of manufacture
(13)	Packing date
(17)	Expiry date
(21)	Serial number
(30)	Quantity in pieces

1.3 Intended use

Main function: Suction of secretions, blood, serous fluids, rinsing fluids and for the temporary collection of these fluids.

Medical indications / application: For all applications where suction is needed, such as in general surgical procedures (e.g. suction of wound cavities, abscesses), the nasopharyngeal cavity, for endoscopy, for suction of secretion or rinsing fluids, and in neurosurgery.
For subcutaneous liposuction.

Specification of the main function: For the drainage and temporary collection of body fluids. By means of an electrical suction pump a negative pressure is created. An additional secretion canister must be attached to allow temporary collection of the derived body fluids.

User profile: Doctors, medical auxiliaries without restrictions.

Patient groups: Patients of all ages with and without restrictions.

Application organ: Natural orifices and openings which result from a surgical intervention (entire body of humans and animals).

Application time: For short term use on patients (< 30 days)

Area of application: The application site is the clinical, outpatient and veterinary field. The device may be used only by persons who have received the relevant training and instruction.

Contraindications: Not suitable for:

- Drainage operations in the low vacuum range (e.g. thoracic or wound drainage)
- Use outside the medical sector
- Suction of flammable, corrosive or explosive substances
- Suction in potentially explosive areas
- Not suitable for use as a vacuum extraction system

The product is: active

Sterility:	No sterile product
Single-use product/ re-sterilisation:	The device and parts of the accessories are reusable. For information on reprocessing, cleaning and disinfection please see the operating instructions.

1.4 Function

The ATMOS Record 55 is a mains-operated surgical suction device, the core of which is a high-performance, maintenance-free diaphragm pump. It generates vacuum in the hose and secretion canister system, which assists in drawing off and collecting the secretions. Via a vacuum regulator with vacuum gauge, the final vacuum and thus the desired suction capacity can be precisely adjusted.

Several secretion canisters of different sizes are available for secretion collection. A mechanical overflow protection on the double hose connector and a bacterial filter in the connecting hose from the secretion canister to the pump prevent the suction of secretion into the pump.

1.5 Intended users

May be used only by trained professionals in supervised and medical operation.

1.6 Scope of delivery

Basic device ATMOS Record 55 with standard rail

Name	REF
1x power cable 5 m	008.0629.0
2x hydrophobic bacterial and viral filter	443.0738.0
1x hose holder	443.0003.0
1x suction hose (silicone), Ø 6 mm, L = 2 m	000.0361.0
1x suction hose (silicone), Ø 10 mm, L = 2 m	000.0243.0
1x suction hose (silicone), Ø 7 mm, L = 0.65 m	006.0008.0

1.7 Transport and storage

Transport the product only in a shipping box that is padded and offers sufficient protection.

If damage occurs during transport:

1. Document and report the transport damage.
2. Send the device to ATMOS; see chapter '6.3 Sending in the device' on page 24.

Environmental conditions for transport and storage: see chapter '10 Technical data' on page 29.

2 Notes for your safety

2.1 General safety instructions

Report all serious incidents that have occurred in connection with this product to the manufacturer and your national competent authority.

The product will only meet the safety requirements of users, patients and third parties when it is fully functional. Therefore, observe the following instructions on your product:

Please read and pay attention to the safety instructions prior to using the product.

2.2 Danger for users, patients and third parties

WARNING

Choking hazard for children due to accessories!

Children can strangle themselves or be suffocated by small parts.

- Keep children away from hoses and connection cables.
- Keep children away from swallowable small parts. Small parts are, e.g. fingertip and sealing ring.

CAUTION

Explosion and fire hazard!

There is a risk of burns and injuries.

- Never suction any explosive, flammable or corrosive gases or liquids. Please observe the intended use in chapter '1.3 Intended use'.
- Never operate the product in potentially explosive areas or in areas that are oxygenated.
- Use only original accessories and original spare parts from ATMOS.

WARNING

Risk of severe injury to your patient.

Avoid improper use.

- The device may be used only by persons who were medically trained and were instructed in the handling of the medical suction system.
- The product may be used only by qualified personnel in supervised operation.
- Please select the vacuum according to the patient and the application.
- Observe the valid guidelines.
- Always set up the device in such a way that the operating elements are in clear view and within easy reach of the operator. The device must be placed on a stable, level surface.

⚠ WARNING

Ensure that the device is always functional and ready for use.

Your patient could suffocate.

- Before connecting the device, it must be checked whether the required mains voltage on the device matches the mains voltage of the mains power supply.
- Position the unit in an easily accessible location and keep access free.
- Make sure that the power cable is working. Replace defective accessories immediately.
- Prior to first use, the transport protection on the bottom of the device must be removed.
- ATMOS recommends always having another suction device ready at hand. Thus, suction is available even in the event of device failure.

⚠ WARNING

Risk of infection due to pathogens on the product!

Deadly diseases can be transmitted.

- In case you come into contact with secretion, disposable gloves should be worn.
- Always wear disposable gloves when using the product.
- Never use components marked with  more than once. These components are intended for single use only.
- Use sterile-packed parts only if the packaging is undamaged.
- Never operate the device without a bacterial filter.
- A suction catheter, suction attachment or medical suction instrument must always be connected to the hose. The suction hose must never come into direct contact with the suction area.
- Clean and disinfect the product after every use.
- Clean and disinfect the product according to the operating instructions.
- The device must not be used following oversuction.

⚠ CAUTION

Tripping hazard by cables.

Injuries are possible.

- Lay connecting cables properly.

⚠ WARNING

Electric shock due to improper mains connection, incorrect handling of the product or damaged product components.

Risk of burns, cardiac arrhythmias and even fatal injury.

- Prior to each use, check for damage to the device and the power cable. Do not operate the device if you notice any damage. In this case, clean and disinfect the device and send it to ATMOS for repair.
- Disconnect the device from the mains supply prior to cleaning or disinfection.
- Disconnection of the device is only possible by removing the power plug from the power supply.
- Position the device so that it can be easily disconnected from the mains power supply.
- Never connect the device to a mains power supply without a protective conductor.
- Never touch the plug or power cable with wet hands.
- Use the power cable only in dry surroundings. The surroundings must be non-conductive.
- Ensure that no liquid penetrates the device. If liquid enters the device, operation of the device must cease immediately. In this case, clean and disinfect the device and send it to ATMOS for repair.
- Use only proper power cables and extension cables.
- Never touch the device interface and the patient at the same time!
- Use only original accessories and original spare parts from ATMOS.
- Please pay attention to the periodic tests in chapter 6.0 'Maintenance and service'.
- Assembly, new settings, alterations, extensions, and repairs may be carried out only by authorised persons.
- Do not modify the device without the manufacturer's permission.

2.3 Avoiding damage to the device

NOTICE

Storage and operation in an unsuitable environment.

Risk of damage to the product.

- Please observe the environmental conditions regarding transport, storage and operation.
- After transporting the device at low temperatures and prior to first start-up, it should be kept at room temperature for at least six hours. If the device is not acclimatised, it may not be used, as damage to the diaphragms of the pump could occur.

3 Setting up and starting up

3.1 Device overview

Front view



- ① Vacuum gauge
- ② Vacuum regulator
- ③ On/off switch
- ④ Bacterial filter and connection piece
- ⑤ Hose holder
- ⑥ Connection for foot switch or foot controller (optional)

Rear view



- ① Connection for potential equalisation
- ② Equipment safety fuse
- ③ Mains supply

⚠ Risk of injury and risk of infection due to production residues.

1. Prior to first use, reprocess the product according to the operating instructions.

4 Operation

4.1 Initial start-up

- ☞ Observe the safety instructions prior to initial start-up!
- ☞ Remove the transport protection on the bottom of the device by loosening the two red marked Allen screws.
- ☞ The transport protection screws must be inserted again before a return transport of the device.
- ☞ After transporting the device at low temperatures, it should be kept at room temperature for at least six hours before initial start-up; otherwise, the device must not be operated.

4.2 Preparing the device

- Check whether the voltage and frequency data listed on the device correspond to the values of the mains power supply and connect it to the mains.
- ☞ For surgical procedures, we recommend additionally connecting the device via the connection to the potential equalisation of the examination room.
- » The device is now ready for use.

4.3 Connecting the bacterial filter



- Insert the bacterial filter with the short piece of hose onto the connection piece on the device.
- ☞ Pay attention to the correct flow direction on the bacterial filter. The type label must point towards the front.

4.4 Attaching the connecting hose



- Attach the connecting hose to the bacterial filter.

4.5 Attaching the secretion canister

1. Attach the secretion canister to the standard rail.
2. Connect the canister lid or double hose connector to the bacterial filter using a hose.
3. First make sure that the secretion canisters are attached in the front area. If additional secretion canisters are required, they can be attached laterally.

4.6 Connecting the suction hose



- Attach the suction hose to the angled connection.

4.7 Serres®, Medi-Vac® secretion canister system, other canister systems

- ☞ Observe the operating instructions by the manufacturer of the corresponding canister system.
- ☞ Do not operate the device without a bacterial filter.

4.8 Secretion canister system

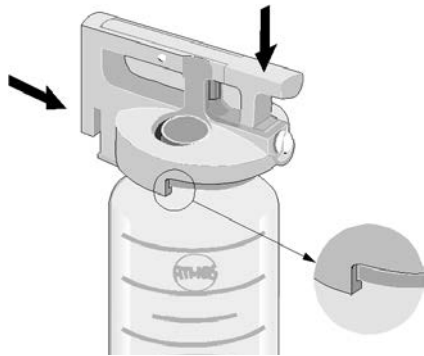

- Slide the canister lid over the secretion canister (make sure the lid edge is over the edge of the canister) and press the locking handle downwards until it engages.
- The canister lid must tightly seal the secretion canister so that the desired vacuum can build up inside the secretion canister.

4.9 Double hose connector



Before inserting the double hose connector, check whether the float for the overflow safety can be easily moved. Then insert the double hose connector into the canister lid. Make sure that it fits tightly.

- ❶ Connection for connecting hose
- ❷ Connection for suction hose
- ❸ Float for the overflow safety

4.10 Using an overflow canister



If the bacterial filter becomes blocked too frequently, ATMOS recommends integrating an additional overflow canister (REF 444.0646.0) between the secretion canister and the bacterial filter. This absorbs moisture and foam bubbles.

An additional DDS bacterial filter can be used in the overflow canister. Replace the bacterial filter (REF 340.0054.0) with a new filter if it is discoloured or contaminated, or if oversuction has occurred. When the filter is used regularly, a filter change is recommended after 14 days at the latest.

4.11 Using a smoke evacuation filter

According to the intended use, the device is used to suction liquids and pieces of tissue. In conjunction with the use of laser, HF or radiosurgical devices, surgical smoke is generated and does not remain in the secretion canister, but is drawn with the air flow in the direction of the pump and can quickly block the bacterial filter for microbiological protection as well as the overflow protection. To increase the life time of the bacterial filter, an activated charcoal filter (REF 008.0758.0) or a specific smoke evacuation filter (HM57524928) can be placed in front of it. This filters the aerosols / ultra-fine particles out of the air stream and protects the bacterial filter.

NOTICE! THE SMOKE EVACUATION FILTER DOES NOT REPLACE THE BACTERIAL FILTER!

The smoke filter, however, prevents a premature decrease in suction performance by blocking the bacterial filter.

4.12 Suction

1. Please ensure that the following parts have been reprocessed before treating a new patient:
 - Suction hose including suction attachment or suction instrument
 - Secretion canister including canister lid and double hose connector
 - Connecting hose
2. Prior to each use, check whether the bacterial filter must be replaced.
3. Replace the bacterial filter with a new bacterial filter if it is discoloured or contaminated, or if oversuction has occurred.
4. Switch on the device.
5. Close the suction hose and set the desired vacuum.
6. Connect the suction catheter, suction attachment or suction instrument.
 - ☞ Observe the liquid level in the secretion canister during suction. The mechanical overflow protection and the bacterial filter prevent liquid from being sucked into the pump. Nevertheless, the secretion canister should be emptied or replaced when it is 2/3 full (including foam crown).
 - ☞ If liquid has been sucked into the pump despite the overflow protection and bacterial filter, the device may not be operated again until it has been checked by an authorised service partner.

4.13 Checking the bacterial filter

NOTICE

The bacterial filter is a disposable product and cannot be autoclaved or disinfected.

- Set the vacuum regulator to 'max'.
 - As soon as the vacuum gauge shows a vacuum value higher than -0.3 bar while the suction hose is open, the bacterial filter must be replaced.
 - To do this, remove the suction connections on the bacterial filter and insert the new bacterial filter. Pay attention to the correct flow direction.
 - Dispose of the used bacterial filter immediately.
- ☞ Always have some spare filters ready to hand!

4.14 Exchanging the secretion canister

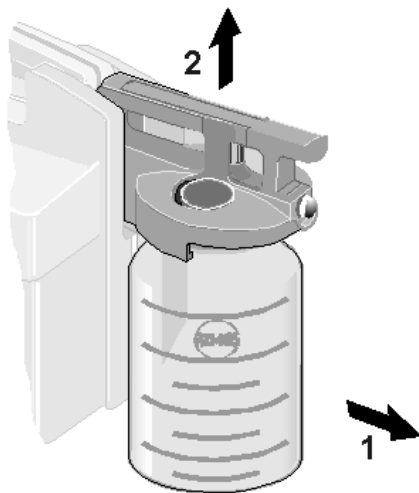

1. Stop the suction process and switch off the device.
2. Remove the double hose connector from the full secretion canister. If you have attached a second canister, insert it and continue the suction process.
3. To remove the secretion canister, first tip it slightly away from the device (1) and then pull it upwards (2).
4. Now either empty it or replace it with a new secretion canister. To open the clamping bracket, put the secretion canister down and press the release button. Dispose of the suction material properly.
5. After use, switch off the device and clean the device and accessories as described in the operating instructions.

4.15 Changing Serres®, Medi-Vac® secretion canister system and other secretion canister systems

- ☞ Observe the operating instructions by the manufacturer of the corresponding canister system.

4.16 Options

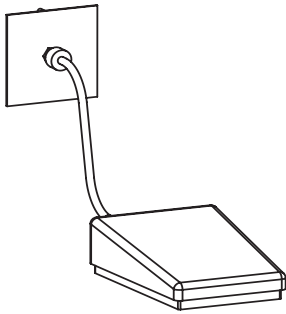

Foot switch REF 443.0755.0

Pneumatically explosion-proof switch for switching the device on and off.

1. Connect the foot switch.
2. Set the main switch in the control panel to foot switch operation (OFF).
3. When you press the foot switch, the device is switched on.
4. When you press the foot switch again, the device is switched off.
 - If the main switch in the control panel is set to continuous operation (ON), the foot switch produces **no** effect.

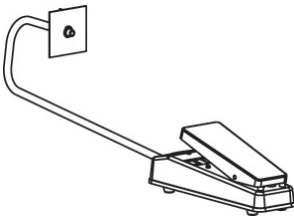

Foot controller REF 443.0770.0

Foot controller for regulating the vacuum.

1. Connect the foot controller (remove the protection cap and tighten the nut of the foot controller hose).
2. To increase the vacuum, press the pedal down.
 - When you lift up your foot, the controller locks in that position.

5 Reprocessing

5.1 Safety instructions for reprocessing

5.1.1 General safety instructions

We recommend that you always document all maintenance work and part replacements in writing.

It is the responsibility of the user to ensure that the required results of cleaning and disinfection are achieved. Validation and routine monitoring of the procedure will generally be necessary.

Reprocessing may be carried out only by persons who have the necessary expertise. To carry out these measures, the person must have the necessary devices.

5.1.2 Danger for users, patients and third parties

Risk of infection due to unsuitable accessories.

Risk of deadly diseases being transmitted.

- Always wear your own personal protective equipment. The protective equipment consists of protective gloves, protective clothing, goggles and mouth and nose protection for all steps in which the product components are still contaminated.
- Use only aids that can be easily reprocessed or ones that are disposable products.

Risk of infection due to unsuitable reprocessing.

Risk of deadly diseases being transmitted.

- Make sure that all areas of the accessories can be easily reached.
- Use only suitable load carriers for mechanical reprocessing. This especially applies to accessories with difficult to access cavities and lumens.
- Make sure that air bubbles do not form in the cavities and lumens of accessories when placing them in the processing solution.

5.1.3 Avoiding damage to the device

Damage to the device due to cleaning with fixatives.

Residues cannot be permanently removed.

- Do not use aldehydes before and during cleaning.
- Do not expose the product to temperatures above 40 °C / 104 °F before and during cleaning.

Unsuitable accessories.

- ☞ Observe the respective operating instructions of all the accessories and devices used.

Unsuitable cleaning agents and disinfectants.

Risk of damage to the product.

- Do not use any process chemicals that contain the following ingredients **on plastic parts**:
 - Chloramides or phenol derivatives
- Do not use any process chemicals that contain the following ingredients **on stainless steel**:
 - Organic or inorganic bases
 - Alkaline solutions

Incorrect mechanical cleaning and disinfection.

Corrosion due to moisture.

- When the programme is finished, remove the products immediately.

5.2 Preparing/completing reprocessing

Prior to reprocessing

1. Disassemble the product for reprocessing into the following items:
 - Device
 - Hoses
 - Secretion canister system

After reprocessing

1. Perform a function check.

5.3 Reprocessing surfaces

5.3.1 Overview

Surface	After each application	After each patient	Daily	Weekly	Every 14 days	Monthly	Pre-cleaning	Wipe cleaning	Wipe disinfection	Spray disinfection	Remarks
Housing	X						X	X			

5.3.2 Selecting process chemicals

Always observe the manufacturer's specifications for the process chemicals.

Cleaning agent (manufacturer)	Active ingredients in 100 g	Type	Housing
Disinfection			
Green&Clean SK (Metasys)	<1 g dialkyldimethylammonium chloride, <1 g alkyldimethylethylbenzylammonium chloride, <1 g alkyldimethylbenzylammonium chloride	Foam Ready to use	x
Dismozon® plus (Bode Chemie)	95.8 g magnesium peroxyphthalate hexahydrate	Granulate	x
Kohrsolin® FF (Bode Chemie)	5 g glutaral, 3 g benzyl C12-C18 alkyldimethylammonium chlorides, 3 g didecyldimethylammonium chloride	Liquid concentrate	x
Kohrsolin® extra (Bode Chemie)	14.1 g (ethylenedioxy) dimethanol, 5 g glutaral, 8 g didecyldimethylammonium chloride	Liquid concentrate	x
perform® (Schülke & Mayr)	45 g pentapotassium bis(peroxymonosulphate) bis(sulphate)	Powder	x
Mikrobac® forte (Bode Chemie)	19.9 g benzyl C12-18-alkyldimethylammonium chloride, 5 g N- (3-aminopropyl) -N-dodecylpropane-1,3-diamine	Liquid concentrate	x
Bacillo® 30 Foam (Bode Chemie)	14 g ethanol, 10 g propan-2-ol, 6 g propan-1-ol, 0.5 g N-alkyl-aminopropylglycine	Foam Ready to use	x
Incidin® Active (Ecolab)	Peracetic acid	Powder	x
mikrozid® sensitive wipes (Schülke & Mayr)	0.26 g alkyl(C12-16)dimethylbenzylammonium chloride, 0.26 g didecyldimethylammonium chloride, 0.26 g alkyl(C12-14) ethylbenzylammonium chloride	Wipes	x

5.3.3 Pre-cleaning

1. Disconnect the device from the mains power supply.
2. Clean the surface evenly with a suitable cloth and clear water. Pay particular attention to hard-to-reach areas.
 - » There is no more residue visible.

5.3.4 Wipe disinfection

Always observe the manufacturer's specifications for the process chemicals.

5.4 Reprocessing the accessories

5.4.1 Overview

Accessories	Disposable product	Max. reprocessing cycles	After each application	After each patient	Daily	Weekly	Every 14 days	Monthly	Pre-treatment	Pre-cleaning	Manual cleaning and disinfection	Mechanical cleaning and disinfection	Sterilisation
Secretion canister system													
• Secretion canister ²		-	X						X	X		X	X
• Canister lid ²		-	X						X	X		X	X
• Double hose connector ²		--	X						X	X		X	X
• DDS bacterial filter ¹	X						X						
Hoses													
• Suction hose		60	X						X	X		X	X
• Vacuum hose		60	X						X	X		X	X
• Connecting hose		60	X						X	X		X	X

¹ Replace the DDS bacterial filter if it is discoloured or soiled, or if oversuction has occurred; see chapter 4.3.

² If there are visible defects or damage, accessories must be replaced.

5.4.2 Selecting process chemicals

Always observe the manufacturer's specifications for the process chemicals.

Cleaning agent (manufacturer)	Active ingredients in 100 g	Type	Secretion canister system	Hoses
Cleaning agents - Mechanical reprocessing				
neodisher® MediClean forte (Dr. Weigert)	<5% nonionic and anionic surfactants, enzymes	Liquid concentrate		X
neodisher® An (Dr. Weigert)	<5% nonionic surfactants, >30% phosphates, enzymes	Powder	X	
Neutraliser				
neodisher® Z (Dr. Weigert)	<5% nonionic and anionic surfactants, enzymes	Liquid concentrate	X	

5.4.3 Secretion canister system

Characteristics

The accessories have the following areas which are difficult to access:

- Double hose connector (lumens)

Take particular care when reprocessing hard-to-reach areas.

<p>Pre-treating at the site of use</p> <ul style="list-style-type: none"> • Flushing: 60 s • Rinsing: 60 s 	<ul style="list-style-type: none"> • Empty the secretion canister. • Clean the accessories under cold, running water. • Thoroughly rinse out the cavities and lumens of the accessories with running water. <p>There is no more residue visible.</p>
<p>Collecting and transporting</p>	<ul style="list-style-type: none"> • Label any damaged accessories. • Place the accessories in a canister. • Transport the canister to the reprocessing site.
<p>Dismantling</p>	<ul style="list-style-type: none"> • See chapter '5.2 Preparing / completing reprocessing' • Dispose of disposable products
<p>Pre-cleaning</p> <ul style="list-style-type: none"> • Flushing: 1x / 30 s • Rinsing: 60 s <p><u>Brush: Round brush</u> Size: 7 mm, material: nylon</p> <p><u>Brush: Round brush</u> Size: 11 mm, material: nylon</p> <p><u>Brush: Round brush</u> Size: 15 mm, material: nylon</p> <p><u>Brush: Square</u> Size: 40 x 10 mm, material: nylon, characteristics: with angled head</p>	<ul style="list-style-type: none"> • Make the following cavities accessible: <ul style="list-style-type: none"> – Double hose connector – Canister lid • Make the following lumens accessible: <ul style="list-style-type: none"> – Double hose connector • Thoroughly clean the accessories evenly with a suitable brush under running water • Thoroughly rinse out the cavities and lumens of the accessories with running water.
<p>Mechanical cleaning and disinfection</p> <p>Pre-rinse: 1 min Cleaning: 5 min, 50 °C / 122 °F Neutralise: 2 min Intermediate rinse: 1 min Disinfect: 5 min, 93 °C / 199 °F Drying: 12 min, 110 °C / 230 °F</p>	<ul style="list-style-type: none"> • Secure the accessories on a suitable load carrier. • Clean and disinfect using a suitable programme: <ul style="list-style-type: none"> – Pre-rinse with cold water – Cleaning with cleaning agent – Neutralisation with neutralising agent – Intermediate rinse with softened, cold water – Disinfection with demineralised water – Drying • Washer-disinfector: according to EN ISO 15883-1 • Programme: Miele Vario TD
<p>Checking and maintaining</p>	<ul style="list-style-type: none"> • Check whether reprocessing was successful using a suitable light magnifier. They must be free of particles and organic material. • If reprocessing was unsuccessful, the procedure must be repeated. • Dispose of damaged accessories or have them repaired.
<p>Assembly</p>	<ul style="list-style-type: none"> • Not necessary.
<p>Function check</p>	<ul style="list-style-type: none"> • Not necessary.
<p>Packaging</p>	<ul style="list-style-type: none"> • Label the accessories. • Pack the accessories using a packaging system according to DIN EN ISO 11607.
<p>Sterilisation</p> <p>Pre-fractionated vacuum: 3x Temperature: 134 °C / 273 °F Time: 5 min Drying: 10 min</p>	<ul style="list-style-type: none"> • Sterilise the accessories using a suitable procedure: <ul style="list-style-type: none"> – Steam sterilisation / autoclaving • Steriliser: according to EN 285
<p>Storage</p>	<ul style="list-style-type: none"> • Observe the environmental conditions; see chapter '10 Technical data'.

5.4.4 Hoses

☞ Take particular care when reprocessing hard-to-reach areas.

Pre-treating at the site of use	<ul style="list-style-type: none"> • Clean the accessories under cold, running water. • Thoroughly rinse out the cavities of the accessories with running water. <p>There is no more residue visible.</p>
Collecting and transporting	<ul style="list-style-type: none"> • Label any damaged accessories. • Place the accessories in a canister. • Close the canister. • Transport the canister to the reprocessing site.
Pre-cleaning	<ul style="list-style-type: none"> • Clean the accessories under running water. • Thoroughly rinse the lumens of the accessories with running water.
Dismantling	Not necessary.
Mechanical cleaning and disinfection Pre-rinse: 1 min Cleaning: 5 min, 55 °C / 131 °F Neutralise: 2 min Intermediate rinse: 1 min Disinfect: 5 min, 93 °C / 199 °F Drying: 12 min, 110 °C / 230 °F	<ul style="list-style-type: none"> • Secure the accessories on a suitable load carrier. • Clean and disinfect using a suitable programme: <ul style="list-style-type: none"> – Pre-rinse with cold water – Cleaning with cleaning agent – Neutralise with cold water – Intermediate rinse with softened, cold water – Disinfection with demineralised water – Drying • Washer-disinfector: according to EN ISO 15883-1 • Adapter: Miele E366/E446 • Programme: Miele Vario TD
Checking and maintaining	<ul style="list-style-type: none"> • Check whether reprocessing was successful using a suitable light magnifier. • If reprocessing was unsuccessful, the procedure must be repeated. • Dispose of damaged accessories or have them repaired.
Assembly	Not necessary.
Function check	Not necessary.
Packaging	<ul style="list-style-type: none"> • Label the accessories. • Pack the accessories using a packaging system according to DIN EN ISO 11607.
Sterilisation Pre-fractionated vacuum: 3x Temperature: 134 °C / 273 °F Time: 5 min Drying: 10 min	<ul style="list-style-type: none"> • Sterilise the accessories using a suitable procedure: <ul style="list-style-type: none"> – Steam sterilisation / autoclaving <p>Steriliser: in accordance with EN 285.</p>
Storage	<ul style="list-style-type: none"> • Observe the environmental conditions; see chapter '10 Technical data'.

6 Maintenance and service

Maintenance, repairs, and periodic tests may be carried out only by persons who have the appropriate technical knowledge and are familiar with the product. The person in question must possess the necessary test devices and original spare parts required to carry out these measures.

ATMOS recommends: Work should be carried out by an authorised ATMOS service partner. This ensures that repairs and tests are carried out professionally, original spare parts are used and warranty claims are maintained. Maintenance, repairs and periodic tests must **not** be performed while the product is being used on the patient.

6.1 Periodic tests

At least every 12 months a repeat test of the electrical safety should be performed according to IEC 62353.

ATMOS recommends conducting this inspection in accordance with the manufacturer's specifications.

6.2 Function check

- Prior to every use, a visual inspection of the device, hoses, secretion canister and device connecting cables must be performed.
- Replace any damaged parts immediately.

6.3 Sending in the device

1. Remove all consumables and dispose of them properly.
2. Clean and disinfect the product and accessories in accordance with the operating instructions.
3. Place any used accessories with the product.
4. Fill in the form QD 434 'Delivery complaint / return shipment' and the corresponding **Decontamination certificate**.
- ☞ This form is enclosed with each delivery and can be found at www.atmosmed.com.
5. Affix the transport protection to the bottom of the device.
6. The device must be well padded and packed in suitable packaging.
7. Place form QD 434 'Delivery complaint / return shipment' and the respective **Decontamination certificate** in an envelope.
8. Affix the envelope to the outside of the package.
9. Send the product in to ATMOS or your dealer.

6.4 Reprocessing by the manufacturer

If you pass on the device to a new owner, the device must be professionally reprocessed. The device may be passed on only in a hygienically and technically safe condition. Observe country-specific regulations.

In Germany, only ATMOS or authorised professionals may reprocess the device for distribution.

7 Troubleshooting

7.1 Remediating malfunctions

The product has been subjected to a thorough quality control in the factory. However, if a fault should occur, you may be able to resolve it yourself.

Error symptom	Possible cause	Remedy
<ul style="list-style-type: none"> • Device does not start 	<ul style="list-style-type: none"> • Power plug fits poorly • No mains voltage • Defective fuse 	<ul style="list-style-type: none"> • Check the connection to the socket and the device • Check main fuse • Exchange the fuse
<ul style="list-style-type: none"> • Not enough power 	<ul style="list-style-type: none"> • Leakage in the hose or in the secretion canister system 	<ul style="list-style-type: none"> • Check the canister lid and hoses for tightness, replace sealing ring on the canister lid if necessary
<ul style="list-style-type: none"> • No suction capacity 	<ul style="list-style-type: none"> • Bacterial filter is blocked (vacuum gauge indicates vacuum) • The float of the overflow protection seals the double hose connector • Secretion or blood was sucked in and the valve plates of the aggregate are stuck together 	<ul style="list-style-type: none"> • Replace the bacterial filter • Check the fluid level in the secretion canister; if necessary, it must be emptied. Clean overflow protection and check float for free movement • In this case, the device must be sent in for repair

8 Accessories

Accessories	REF
Foot switch	443.0755.0
Foot control for ATMOS Record 55	443.0770.0
Cable for potential equalisation	008.0596.0
Secretion canister 1.5 l (PC)	444.0100.0
Secretion canister 2.5 l (PC)	444.0099.0
Secretion canister lid	444.0650.0
Secretion canister lid incl. standard rail holder	444.0015.0
Socket nipple set	444.0640.0
Double socket nipple with overflow electrode	444.0012.0
ATMOS-External Canister 1 l	401.0100.0
ATMOS-External Canister 2 l	401.0200.0
ATMOS-External Canister 3 l	401.0300.0
Serres®-external canister 1 l	312.0465.0
Serres®-external canister 2 l	310.0402.0
Serres®-external canister 3 l	310.0403.0
Standard rail clamp Serres® complete	444.0484.0
Receptal®-external canister 1.5 l	310.0221.0
Receptal®-external canister 2 l	443.0256.0
Receptal®-external canister 3 l	444.0157.0
Receptal®-holder for standard rail, 1 x 2 l	444.0160.0
Receptal®-holder for standard rail, 1 x 3 l	444.0170.0
Receptal®-holder for standard rail, single	444.0150.0
Receptal®-holder for standard rail, double	444.0156.0
Standard rail support Receptal®	HM57525661
Receptal®-adapter for tissue collector	444.0148.0
Medi-Vac®-external canister 1 l	312.0473.0
Standard rail support Medi-Vac®	444.0451.0
Vacuum shift	HM57522049
Rail clamp for equipment mount, plastic	HM57522540
Rail clamp for equipment mount, metal	HM57522048
Safety canister 250 ml (without hydrophobic DDS bacterial filter)	444.0646.0
Safety canister 250 ml (with hydrophobic DDS bacterial filter)	444.0646.1
Hose bracket, for attaching to standard rail	444.0450.0
Hose bracket, stainless steel	320.0611.0
Support for carbon filter, not autoclavable	444.0660.0
Deposit tray, stainless steel	443.0790.0
Bowl, diameter 20 cm	HM57524538
Basket, dimensions 170 x 130 x 85 mm	HM57508012
Catheter holder for trolley, dimensions 150 x 100 x 480 mm	HM57508002
Catheter holder, dimensions 90 x 90 x 350 mm	HM57505157
Catheter tubular	HM57525150
Cover for catheter tubular	HM57525151

Consumables	
Bacterial filter for ATMOS DDS secretion canister, 10 pcs.	340.0054.0
Hydrophobic bacterial and viral filter, Ø 11 mm	443.0738.0
Hydrophobic bacterial and viral filter, Ø 8 mm	444.0628.0
Smoke evacuation filter	HM57524928
Suction hose, PVC, disposable, Ø 8 mm, L = 2.10 m, 50 pcs.	006.0059.0
Suction hose, silicone, Ø 6 mm, L = 1.30 m, 1 pc.	000.0013.0
Suction hose, silicone, Ø 6 mm, L = 2 m, 1 pc.	000.0361.0
Suction hose, silicone, Ø 6 mm, 1 m (minimum 5 m)	006.0009.0
Suction hose, silicone, Ø 10 mm, L = 1.3 m, 1 pc.	318.1012.0
Suction hose, silicone, Ø 10 mm, L = 2 m, 1 pc.	000.0243.0
Suction hose, silicone, Ø 10 mm, 1 m (minimum 5 m)	006.0026.0
ATMOS-Suction Bag 1 l with Gelling Agent, 100 pcs.	401.0101.0
ATMOS-Suction Bag 1 l, 100 pcs.	401.0102.0
ATMOS-Suction Bag 2 l with Gelling Agent, 100 pcs.	401.0201.0
ATMOS-Suction Bag 2 l, 100 pcs.	401.0202.0
ATMOS-Suction Bag 3 l with Gelling Agent, 70 pcs.	401.0301.0
ATMOS-Suction Bag 3 l, 70 pcs.	401.0302.0
Serres®-suction bag 1 l, 36 pcs.	312.0466.0
Serres®-suction bag 1 l, gelling agent, 32 pcs.	312.0467.0
Serres®-suction bag 2 l, 24 pcs.	310.0410.0
Serres®-suction bag 2 l, gelling agent, 22 pcs.	310.0400.0
Serres®-suction bag 3 l, 24 pcs.	310.0411.0
Serres®-suction bag 3 l, gelling agent, 20 pcs.	310.0401.0
Serial tube 287 mm with angle blue	HM57522085
Vacuum serial tube silicone, 175 mm	HM57522084
Receptal®-suction bag 1.5 l, w/o filter, 50 pcs.	310.0222.1
Receptal®-suction bag 1.5 l, with filter, 50 pcs.	310.0222.2
Receptal®-suction bag 2 l, w/o filter, 50 pcs.	443.0257.0
Receptal®-suction bag 2 l, with filter, 50 pcs.	443.0257.2
Receptal®-suction bag 3 l, w/o filter, 50 pcs.	444.0153.0
Receptal®-suction bag 3 l, with filter, 50 pcs.	444.0154.0
Medi-Vac®-suction bag 1 l, 50 pcs.	312.0474.0
Tissue collector 300 ml, disposable	340.0061.0
Carbon filter	008.0758.0
Hose connector for reducing from Ø 10 mm to Ø 6 mm	000.0239.0
Gasket for canister lid	055.0070.0

9 Disposal

Packaging

1. Please recycle the product packaging.

Secretion and blood

1. Please dispose of secretion, blood and contaminated parts in line with country-specific regulations.

In the Federal Republic of Germany, the requirements of the 'Implementation Aid for Disposal of Waste from Healthcare Institutions' apply, a statement issued by the Federal / State Working Group on Waste.

Secretion canister system

Disposable products may not be reprocessed and may not be reused! Please dispose of disposable products professionally.

The following notes apply only to reusable products.

1. Clean and disinfect the reusable products of the canister system.
2. Recycle the disinfected reusable products.

ATMOS Record 55

Do not dispose of the product together with household waste.

The product does not contain any hazardous materials.

1. Clean and disinfect the device.
2. Dispose of the product professionally and according to country-specific laws and regulations.

The housing is fully recyclable. However, please observe country-specific laws and regulations.





9.1 Expected service life

When used according to the operating instructions, the device (ATMOS Record 55 with standard rail) has an expected service life of 8 years. Regular thorough cleaning and disinfection of the suction device and its applied parts as well as operation of the device according to the operating instructions are assumed.

10 Technical data

Input voltage	230 V~, 50/60 Hz
Current consumption	approx. 0,45 A (230 V~)
Power consumption	100 VA (230 V~)
Fuses	T 630 mA/H (230 V~)
Vacuum regulator	Mechanical valve
Noise level	Free flow: 49 dB (A) @ 1m (acc. to ISO 3774) End vacuum: 39 dB (A) @ 1m (acc. to ISO 3774)
Max. vacuum at NN	-98 kPa* (-980 mbar) * 1 bar \cong 750.06 mmHg \cong 1000 hPa / dependent on daily air pressure
Vacuum display	-1...0 bar (\pm 2,5 % of the final value)
Suction capacity of pump	55 \pm 3 l/min
Secretion canister	1,5 l / 2,5 l Polycarbonate canisters Supports for using disposable bags: <ul style="list-style-type: none"> • ATMOS (1 l / 2 l / 3 l) • Receptal® (1 l / 1,5 l / 2 l / 3 l) • Serres® (1 l / 2 l / 3 l) • Medi-Vac® (1 l / 1,5 l / 3 l)
Suction tubing	\varnothing 6 mm, 2 m long \varnothing 10 mm, 2 m long
Power cable	Length: 5 m
Operating time	> 8 h continuous
Operating time	Continuous operation
Protective earth conductor resistance	max. 0,1 Ω
Earth leakage current	N.C. < 0,5 mA
Touch current	N.C. < 0,1 mA
Patient leakage current	----
Environmental conditions: Transport/storage <ul style="list-style-type: none"> • Temperature range • Air humidity without condensation • Air pressure 	-30...+50° C 5...90 % 700..1060 hPa
Environmental conditions: Operation <ul style="list-style-type: none"> • Temperature range • Air humidity without condensation • Air pressure 	+10...+32° C 20...80 % 700...1060 hPa
Maximum operating altitude	3000 m
Contamination level	2
Overvoltage category	II
Dimensions (H x W x D)	940 x 500 x 390 mm (without secretion canister)
Weight	24 kg (without secretion canister)

Periodic tests	Repeat test of the electrical safety every 12 months. Recommended: Inspection according to the manufacturer's specifications.
Classification of applied parts	Type BF applied parts 
Degree of protection	IPX 1
CE marking	
Reference number (REF)	443.0700.0

Hydrophobic bacterial and viral filter

Protection against bacteria (BFE)	Filtration efficiency: 99.89667 %*
Protection against viruses (VFE)	Filtration efficiency: 99.0 %*
Filter class	H13 (High-Efficiency Particulate Air/Arrestance)*

*External test report (test laboratory)

11 Notes on EMC

☞ Medical electrical equipment is subject to special precautions with regard to EMC and must be installed according to the following EMC notes.

Guidance and manufacturer's declaration – ambient conditions

The ATMOS Record 55 is suitable for use in the following environments:

- In professional healthcare facilities such as medical practices, hospitals/clinics, first-aid facilities and operating theatres/rooms. Not suitable is the environment of HF surgical devices and outside of an RF-shielded room of a magnetic resonance imaging system.
- Special environments such as factory or military facilities and medical areas near HF surgical devices, short-wave therapy equipment or within an RF-shielded room of a magnetic resonance imaging system.

The customer or user of the ATMOS Record 55 must ensure that it is used in such an environment.

Guidance and manufacturer's declaration – key features

☞ Please note the technical data in this manual. The essential features are fully usable even in the presence of electromagnetic disturbances.

Guidance and manufacturer's declaration – for accessories, transducers, and cables

The ATMOS Record 55 has the following electrical components:

Type	REF	Max. cable length
Power cable	008.0629.0	5 m

Guidance and manufacturer's declaration – warnings

WARNING

The use of third-party accessories, transducers and cables as specified or provided by the manufacturer may result in increased electromagnetic emissions or reduced immunity to electromagnetic interference and result in erroneous operation.

WARNING

Portable RF communications equipment (e.g., radios, antenna cables) should be used no closer than 30 cm* to any parts of the ATMOS Record 55, including cables, specified by the manufacturer. Otherwise, this can lead to a reduction in the device's performance.

☞ * At higher immunity test levels the distance may be reduced.

WARNING

Placement on or next to another device should be avoided. This could result in incorrect operation. If this is unavoidable, the proper functioning of the device must be monitored regularly. If possible, please switch off any nearby devices that are not in use.



MedizinTechnik

ATMOS MedizinTechnik GmbH & Co. KG

Ludwig-Kegel-Str. 16

79853 Lenzkirch / Germany

Phone: +49 7653 689-0

info@atmosmed.com

www.atmosmed.com