

Instructions for Use

ATMOS E 341 Battery

English



Table of contents

1.0	Introduction	4
1.1	Information on instructions for use	4
1.2	Explanation of pictures and symbols	5
1.3	Intended purpose	8
1.4	Function	10
1.5	Intended operators	10
1.6	Scope of delivery	11
1.7	Transport and storage	12
2.0	Notes for your safety	13
2.1	General safety information	13
2.2	Danger for users, patients and third parties	13
2.3	Damage to the device	15
3.0	Setting up and starting up	16
3.1	Device overview	16
3.1.1	Front and rear view	16
3.1.2	Control panel	18
3.2	Preparing the device	18
3.3	Charging the battery	19
3.4	Connection and removal of canister system and hoses	20
3.4.1	DDS canister system	20
3.4.2	Serres® canister system	23
3.4.3	Medi-Vac® canister system	26
3.5	Support for canister system	27
3.5.1	DDS canister system	27
3.5.2	Serres® canister system	29
3.5.3	Medi-Vac® canister system / Universal bracket	30
3.6	Hose rewind	31
3.7	Device base	31
4.0	Operation	33
4.1	Switch on the device	33
4.2	Switch off the device	33
4.3	Vacuum adjustment	33
4.4	Suction	34
5.0	Cleaning and disinfection	36
5.1	Prepare for cleaning	36
5.2	Cleaning	36
5.3	After cleaning	38
5.4	Recommended disinfectants	39
5.4.1	Instrument disinfection	39
5.4.2	Surface disinfection	39
5.4.3	Pre-cleaning	40
5.4.4	Wipe cleaning	40
5.4.5	Wipe disinfection	40

5.5	Reprocessing the accessories	40
5.5.1	Overview	40
5.5.2	Secretion canister system	41
5.5.3	Hoses	42
5.6	Oversuction	43
6.0	Maintenance and service	44
6.1	Periodic tests	44
6.2	Function check	44
6.2.1	Manual function check	44
6.2.2	Automatic function check	45
6.3	Sending in the device	46
6.4	Handling of batteries	46
6.4.1	Battery	46
6.4.2	Device with built-in battery	46
6.5	Battery exchange	47
6.6	Exchange release button	48
7.0	Eliminating errors	50
8.0	Accessories and consumables	53
8.1	Wall and device support	54
8.2	Retrofit kit canister system	55
9.0	Disposal	56
10.0	Technical data	57
11.0	Notes on EMC	61
12.0	Notes	62

1.0 Introduction

1.1 Information on instructions for use



These instructions for use contain important notes on how to operate the ATMOS E 341 Battery safely, correctly and effectively.

The instructions are intended for the training and teaching of operating personnel and are intended as a reference. Reproduction, even partial, is only permitted with written permission from ATMOS.

These instructions for use must always be kept available near the device.



Care, periodic tests, regular cleaning and proper application are indispensable. They guarantee the operational safety and usability of the ATMOS E 341 Battery.

Maintenance, repairs and periodic tests may only be carried out by persons who have the appropriate technical knowledge and are familiar with the product. To carry out these measures the person must have the necessary test devices and original spare parts.



Prior to start-up please peruse chapter “2.0 Notes for your safety” on page 13, in order to be prepared for any possible dangerous situations. This helps you avoid potentially dangerous situations.

The product ATMOS E 341 Battery bears CE marking CE 0124 in accordance with EC Council Directive 93/42/EEC concerning medical devices and meets the basic requirements of Annex I to this directive.

The product ATMOS E 341 Battery complies with all applicable requirements of the Directive 2011/65/EU restricting the use of certain hazardous substances in electrical and electronic equipment (“RoHS”).

The Declaration of Conformity and our general standard terms and conditions can be obtained on our website at www.atmosmed.com.

The quality management system at ATMOS has been certified according to international standards EN ISO 13485.









These instructions for use are valid for the following devices:

ATMOS E 341 Battery	REF 319.0000.0
ATMOS E 341 Battery / DDS	REF 319.1000.0
ATMOS E 341 Battery / Serres®	REF 319.1100.0
ATMOS E 341 Battery / Medi-Vac®	REF 319.1200.0
ATMOS E 341 Battery / Universal bracket	REF 319.1300.0









Some figures show the ATMOS C 341 Battery. However, the devices do not differ in their functionality described.

















1.2 Explanation of pictures and symbols















In the instructions for use

 DANGER	Warning of a danger which causes immediate death or serious injury. Observe the necessary measures.
 WARNING	Beware of a danger which can cause death or serious injury. Observe the necessary measures.
 CAUTION	Beware of a danger which can easily hurt you. Observe the necessary measures.
NOTICE	Indication of a danger where the product or other items can be damaged. Observe the necessary measures.
	Warning of a danger which can cause death or serious injury.
	Information regarding possible material damage which can be caused.
	Useful information on the handling of the device.
1.	Action. Go step by step
•	Numeration.
»	Result of an action.
	Move, plug in this direction.
	Engage, check correct fit.

On device, type plate, and packaging

	Follow instructions for use (blue)
	Consult instructions for use
	Warning, special diligent notice
	This device complies with the relevant requirements of EU regulations.
	This device complies with the relevant requirements of EU regulations.
	UK only: UKCA marking (UK Conformity Assessed confirms that the product conforms to UK regulations)
	Manufacturer
	Date of manufacture

	Date of manufacture Country of manufacture
	Distributor
REF	Reference number
UDI	Unique Device Identifier of a medical device
MD	Medical device
SN	Serial number
LOT	Batch code
IP34D	Specification of the degree of protection against the ingress of solids and moisture
	Applied part type BF
	For indoor use only
	Professional disposal
	Contains lead, recyclable
	European Recycling Platform
	Use-by date
	Do not reuse
	Non-sterile
STERILE 	Sterilized using ethylene oxide
	Single sterile barrier system
PATIENT	Connection suction hose/patient (Serres® canister system)
	Mounting position: on the top
	Do not throw into fire
	Device does not contain latex
	Short-term operation

	Protection class II device
	Output voltage
	Input voltage
	Alternating current
	Direct current
	On/off button
	Button battery status
	This side up
	Handle with care
	Fragile, handle with care
	Keep dry
	Keep away from sunlight
	Temperature limit
	Humidity limitation
	Atmospheric pressure limitation

UDI application identifier

(01)	UDI-DI: Identification of the manufacturer and the device
(10)	Batch code
(11)	Date of manufacture
(13)	Packing date
(17)	Expiry date
(21)	Serial number

1.3 Intended purpose

Product name:	<ul style="list-style-type: none"> • ATMOS E 341 Battery / DDS • ATMOS E 341 Battery / Serres® • ATMOS E 341 Battery / Medi-Vac® • ATMOS E 341 Battery with universal bracket
Main functions:	<p>Temporary and spontaneous suction of aspirate (i.e., secretion, blood, serous fluids, and body fluids as well as thin, viscous, and solid pieces of food) from the oral cavity, pharynx, and the bronchial system</p> <p>For deflating vacuum mattresses and inflatable splints</p>
Intended use:	Suction of the upper and lower respiratory tract
Intended users / user profile:	<ul style="list-style-type: none"> • Doctors • Healthcare professionals • Rescue service staff • Non-medical users, e.g. patients and/or relatives (after instruction by a doctor) <p><u>Please note:</u> The device may only be used by persons who possess medical training and have been instructed in suction techniques</p>
Intended patient target groups:	Patients of all age groups with and without restrictions
Medical conditions to be diagnosed, treated or monitored:	Not applicable
Organ(s) applied to:	<ul style="list-style-type: none"> • Upper respiratory tract (nose, nasal cavity, pharynx) • Lower respiratory tract (larynx, trachea, bronchial system)
Duration of application:	Temporary use on the patient (< 60 min)
Use environment:	<ul style="list-style-type: none"> • Hospitals, clinics, practices, emergency situations as well as nursing and homecare operation • Emergency or rescue operations • Use outdoors and during transport
Patient selection criteria:	Patients who benefit from suction of the upper and/or lower respiratory tracts

Indications:	<ul style="list-style-type: none"> • Suction of blood, secretion, and pieces of food from the oral cavity, pharynx, and the bronchial system • Suction in case of muscular and/or neurological diseases: <ul style="list-style-type: none"> - suction in the case of dysphagia • In cases of damage to respiratory and coughing functions with dysfunctional elimination of tracheal, bronchial, or oral secretion: <ul style="list-style-type: none"> - suction after tracheotomy - suction after laryngectomy - suction in case of impaired respiratory function
Medical contra- indications:	<p>Not suitable for:</p> <ul style="list-style-type: none"> • continuous operation in cases of drainage in the low-vacuum range (e.g., cardiothoracic drainage or wound drainage) • permanent endoscopic use • vacuum extraction • smoke evacuation • liposuction
Other contra- indications:	<p>Not suitable for:</p> <ul style="list-style-type: none"> • suction of flammable, corrosive, and explosive substances • suction in potentially explosive atmospheres • suction in medical rooms where a potential equalisation is required (e.g., heart surgery) • suction outside of medical areas
Warnings:	<ul style="list-style-type: none"> • The following complications may arise during suction: <ul style="list-style-type: none"> • nasopharyngeal bleeding • vocal cord injuries • tracheal injury • hypoxaemia • cardiovascular instability • bradycardia, arrhythmia, and asystole (provoked by vagus nerve stimulation) • tachycardia (provoked by stress) • gagging, nausea, vomiting, and coughing • hospital-acquired infection (HAI) of the airways • seizures in patients prone to convulsions
The product is:	active
Sterility / specific micro- bial state:	Non-sterile device
Single-use device / reprocessing:	The device is intended for multiple use. The device and parts of the accessories are reusable. For information on reprocessing, cleaning and disinfection, please see the operating instructions.

1.4 Function

General description

The ATMOS E 341 Battery is a mobile, portable, mains-operated medical device for the temporary application on adults, children and babies. The device is operated with an electronically controlled, maintenance-free diaphragm pump.

The pump can be optionally operated by rechargeable battery or via an external DC voltage source (12 V).

Principles of operation and its mode of action

During operation the pump generates a vacuum within the hose system and the secretion canister system. This vacuum is sucking off aspirate (i.e., secretion, blood, body fluids as well as liquid, viscous and solid pieces of food) into the canister system.

The predefined vacuum values enables a quick and precise adjustment of the vacuum in different situations. It can be selected between four different vacuum values (-0.1 bar; -0.2 bar; -0.5 bar and -0.8 bar). The control panel is illuminated so that you can read the operating status even in the dark.

An overtemperature stop prevents overheating of the batteries.

DDS secretion canister:

The DDS secretion canister is affixed laterally to the device and is plugged via Direct Docking onto the suction connection at the support for the DDS canister system. Therefore there is no intermediate hose. Now the user must only connect the suction hose. The aspirate is transported to the reusable secretion canister via the reusable suction hose. A hydrophobic DDS bacterial and viral filter located in the canister lid prevents bacteria, viruses and liquids from entering the device.

A mechanical oversuction stop (float ball) is integrated in the canister lid. This prevents an accidental absorption of secretion into the pump head. The float ball rises to the top of the secretion until it blocks the outlet.

Disposable secretion canister:

The disposable secretion canister is comprised of an external canister, disposable suction bag, vacuum hose and the disposable suction hose.

The disposable secretion canister is affixed laterally to the device. The vacuum hose of the canister is connected to the suction connection of the device. The secretion is transported to the disposable suction bag via the suction hose. The disposable suction bag is a single use product. As soon as the disposable suction bag is full it is removed from the external canister and disposed of. The disposable suction bag and the disposable suction hose must not be reused.

A bacterial filter is integrated in the disposable suction bag. This prevents secretion, liquid and bacteria from seeping into the device.

1.5 Intended operators

The ATMOS E 341 Battery may only be used by persons who were medically trained, and were trained in medical suction. Prior to application the user must be familiar with the device. Please note the country-specific requirements and regulations.

The ATMOS E 341 Battery may be used by the patient himself or a family member after he has been instructed by a doctor.

The suction is carried out after the patient or the assistant/carer has been instructed by the doctor, taking into account the vacuum that is specifically required depending on the age.

Prior to application, the user must be familiar with the device. Please note the country-specific requirements and regulations.

ATMOS recommends: Instruction on the operation of the device must be performed by an authorized person.

1.6 Scope of delivery

☞ Please compare the contents on completeness immediately upon receipt (see delivery note).

319.1000.0 ATMOS E 341 Battery / DDS

1 x basic device with device base and hose reel	319.0000.0
1 x battery for ATMOS E 341 Battery	319.0015.0
1 x power supply and recharging unit for ATMOS C / E 341 Battery	318.0035.0
1 x 2-pin power cable, L = 1.5 m	008.0920.0
1 x support for DDS canister system	318.1010.0
1 x suction hose, silicone, Ø 10 mm, L = 1.30 m	318.1012.0
1 x fingertip for suction hose, Ø 10 mm, 10 pcs.	318.1100.0
1 x DDS secretion canister, 1 l	318.1013.0
1 x DDS entire secretion canister lid	318.1016.0
1 x hydrophobic DDS bacterial and viral filter, 10 pcs.	340.0054.0
1 x instructions for use	GA1GB.320102.0

319.1100.0 ATMOS E 341 Battery / Serres®

1 x basic device with device base and hose reel	319.0000.0
1 x battery for ATMOS E 341 Battery	319.0015.0
1 x power supply and recharging unit for ATMOS C / E 341 Battery	318.0035.0
1 x 2-pin power cable, L = 1.5 m	008.0920.0
1 x support for Serres® canister system	318.1210.0
1 x Serres® external canister 1 l	312.0465.0
1 x vacuum hose for disposable canister system	318.1211.0
1 x instructions for use	GA1GB.320102.0

319.1200.0 ATMOS E 341 Battery / Medi-Vac®

1 x basic device with device base and hose reel	319.0000.0
1 x battery for ATMOS E 341 Battery	319.0015.0
1 x power supply and recharging unit for ATMOS C / E 341 Battery	318.0035.0
1 x 2-pin power cable, L = 1.5 m	008.0920.0
1 x support for Medi-Vac® canister system	318.1500.0
1 x Medi-Vac® external canister 1 l	312.0473.0
1 x vacuum hose for disposable canister system	318.1211.0
1 x instructions for use	GA1GB.320102.0

319.1300.0 ATMOS E 341 Battery / universal bracket

1 x basic device with device base and hose reel	319.0000.0
1 x battery for ATMOS E 341 Battery	319.0015.0
1 x power supply and recharging unit for ATMOS C / E 341 Battery	318.0035.0
1 x 2-pin power cable, L = 1.5 m	008.0920.0
1 x Support for Medi-Vac® canister system	318.1500.0
1 x vacuum hose for disposable canister system	318.1211.0
1 x instructions for use	GA1GB.320102.0

☞ A hydrophobic DDS bacterial and viral filter is not included in the scope of delivery and must be ordered separately for use with a canister system without an integrated bacterial filter.

Not included in the scope of delivery:

- Suction catheter
- Adapter for vacuum mattresses
- Serres® disposable suction bag 1 l without gelling agent 321.0466.0
- Serres® disposable suction bag 1 l with gelling agent 312.0467.0
- Medi-Vac® disposable suction bag 1 l 312.0474.0
- Suction hose, PVC, CH 30, L = 1.30 m, 10 pcs. 006.0057.0
- Wall and device support 318.1250.0

1.7 Transport and storage

Only transport the device in a shipping container, which is padded and offers sufficient protection.

If damage occurs during transport:

1. Document and report the transport damage.
2. Fill in the form QD 434 "Customer complaint/return shipment". This form is enclosed with each delivery and can be found at www.atmosmed.com.
3. Send the device to ATMOS (see chapter "6.3 Sending in the device" on page 46).

Environmental conditions for transport and storage: see chapter "10.0 Technical data" on page 57.

2.0 Notes for your safety

The safety of the ATMOS E 341 Battery complies with all the recognised rules of technology and the guidelines of the Medical Devices Act.

Read and follow the safety instructions carefully before using the product.

2.1 General safety information

Report all serious incidents that have occurred in connection with this product to the manufacturer and your national competent authority.

Make yourself familiar with the device at an early stage, so you can use it even in hectic situations.

Only a fully functional product will meet the safety requirements of users, patients and third parties. Please therefore read the following instructions carefully.

Never operate the unit, if it shows any obvious safety defects. Check the unit at regular intervals for safety and function.

2.2 Danger for users, patients and third parties

WARNING

Take care that the device is always functional and ready for use.

Your patient may suffocate.

- Ensure that the device is always ready for use in an emergency.
- Position the unit in an easily accessible location and keep access free.
- Make sure that the charging accessories are functional. Replace defective charging accessories immediately.
- Recharge the battery at the latest after 6 months, even if you do not use the device.
- Perform a function check after each use. Perform a function check every 4 weeks in case you do not use the device for a longer period.
- ATMOS recommends always having another suction device ready to hand in case of any device failure. So you can suck even in the event of equipment failure.
- Please observe the notes on electromagnetic compatibility (EMC) of the device.
- Use only original accessories and original spare parts from ATMOS.

WARNING

Avoid misapplication.

Your patient may be seriously injured.

- The ATMOS E 341 Battery may only be used by persons who were medically trained, or have been instructed by a doctor.
- Using the device on children requires a lower vacuum setting. Observe the instructions issued by the attending physician.
- Employ the device only according to its intended use.
- Never use the device for low-vacuum suction.
- Too many suction operations may cause minor bleeding.
- Observe the valid guidelines.

WARNING

Reduce the risk of infection for you and your patients!

Deadly diseases can be transmitted.

- Always wear disposable gloves, if you could come into contact with secretion.
- Never use components marked with  more than once. These components are intended for single use only.

- Only use sterile packaged parts, when the packaging is undamaged.
- Never operate the device without hydrophobic DDS bacterial and viral filter. Always check that the bacterial and viral filter in the hydrophobic DDS bacterial and viral filter cartridge is dry and clean before using the device to ensure that it will operate correctly.
- Always use a suitable sterile suction catheter for suctioning. The suction hose must never come into direct contact with the application site.

⚠ WARNING

Protect yourself against an electric shock.

Burns, cardiac arrhythmias and even death are possible.

- Do not operate the device if it has been dropped. In this case please clean the device and send it in to ATMOS for repair.
- Disconnect the device from the mains power supply prior to cleaning or disinfection.
- Prior to each use, please check whether the device or the recharging accessories are damaged. Never operate the device if you detect any failure. In this case please clean the device and send it in to ATMOS for repair.
- Take care that no liquid penetrates the device. In case that liquid has penetrated the device it may no longer be operated. In this case please clean the device and send it in to ATMOS for repair.
- The ATMOS E 341 Battery cannot be sterilised.
- Use the recharging accessories in dry surroundings. The surroundings must be non-conductive.
- Only use the recharging accessories according to the instructions for use.
- Only use original accessories and original spare parts from ATMOS. This specifically applies to the recharging accessories and the battery.
- Please pay attention to the periodic tests in chapter “6.0 Maintenance and service” on page 44.
- Assembly, new settings, modifications, extensions, and repairs may be carried out only by authorised persons.
- Do not modify the device without permission of the manufacturer.

⚠ WARNING

Explosion and fire hazard!

Burns and injuries are possible.

- Never suction any explosive, flammable or corrosive gases or liquids. Refer to the explanations under intended purpose (“1.3 Intended purpose” on page 8).
- Never operate the device in explosion-hazardous areas or areas which are oxygenated.
- Only use original accessories and original spare parts from ATMOS. This specifically applies to the recharging accessories and the battery.

⚠ WARNING

Danger of suffocation and strangulation for children through accessories!

Children can suffocate or be injured by small parts.

- Children can strangle themselves through hoses or power supply cables, especially if the hoses or cables are too long.
- Keep children away from swallowable small parts. Small parts are, e.g. fingertip and sealing ring.
- Keep unauthorised persons away from the device during suction.
- Keep the device and all its accessories out of reach of children until the next use.

⚠ WARNING

Tripping hazard by cables.

Injuries and fractures are possible.

- Lay connecting cables properly.

⚠ WARNING

Contact may cause allergic reactions!

The materials used have been tested for their tolerability. In very rare cases, contact with accessible materials on the device and its accessories may cause allergic reactions. This applies in particular to contact injuries in conjunction with prolonged contact. If this occurs, seek medical attention immediately.

2.3 Damage to the device

NOTICE

Storage and operation in an unsuitable environment!

The device may become damaged.

- Please observe the environmental conditions regarding transport, storage, operation, and charging of the battery; see chapter "10.0 Technical data" on page 57.
- If possible, avoid transport at temperatures below -5 °C . After transport at temperatures below -5 °C : The device must be acclimatized for up to 6 hours at room temperature before you continue with the next steps.

NOTICE

Damage to the device due to improper use!

The device may become damaged.

- Take care that no liquid penetrates the device. In case that liquid has penetrated the device it may no longer be operated. In this case please clean the device and send it in to ATMOS for repair.
- Always place the device on firm, level surface. The device must always be in a vertical position, when you use it.
- Use only power cables and extension cords that function properly.
- The device may only be connected to the mains power supply when mains voltage and frequency of device and mains power supply correspond.
- Switching on the device at a vacuum of -0.8 bar may damage it. Do not switch on the device when the maximum vacuum applied is -0.8 bar .

NOTICE

Damage to device due to heat build-up!

The device may become damaged.

- Do not cover the device during suction.
- Keep the device and the power supply and recharging unit away from other heat sources.
- Do not place the device directly next to other devices as this may cause excessive heating of the device.

3.0 Setting up and starting up

NOTICE

Please observe that insufficient battery charge can result in damage to the battery.

1. The battery must be fully charged prior to first use.

3.1 Device overview

3.1.1 Front and rear view

With DDS canister system



- ① Control panel
- ② Battery compartment cover
- ③ Device base

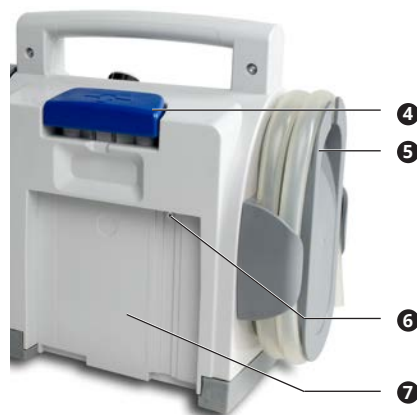

- ④ Release button wall and device support
- ⑤ Hose reel with suction hose
- ⑥ Connection charging accessories
- ⑦ Guide for the wall and device support

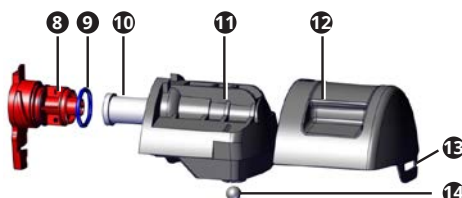

- ⑧ Filter holder
- ⑨ Sealing ring
- ⑩ Hydrophobic DDS bacterial and viral filter
- ⑪ Inner canister lid
- ⑫ Outer canister lid
- ⑬ Canister lid lug
- ⑭ Float ball



- ⑮ Secretion canister with scaling
- ⑯ Connection suction hose
- ⑰ Support for DDS canister system

With Serres® canister system



- ⑧ Angle (connection for the disposable suction hose)
- ⑨ Serres® suction bag
- ⑩ Serres® external canister
- ⑪ Support for Serres® canister system
- ⑫ Grey angle on the Serres® external canister (connection vacuum hose)
- ⑬ Vacuum hose with angled connection

With Medi-Vac® canister system

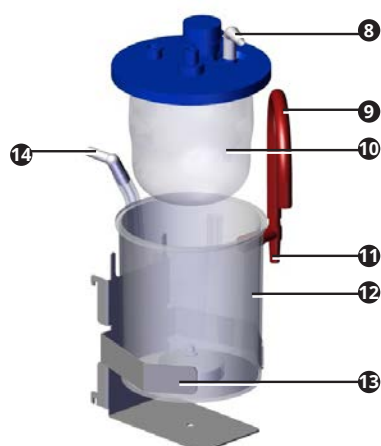

- ⑧ Angle (connection for the disposable suction hose)
- ⑨ Red hose
- ⑩ Medi-Vac® suction bag
- ⑪ Vacuum hose connection
- ⑫ Medi-Vac® external canister
- ⑬ Support for Medi-Vac® canister system
- ⑭ Vacuum hose with angled connection

With universal bracket

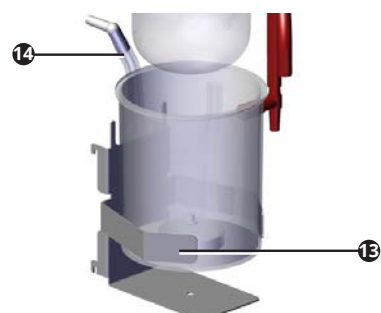

- ⑬ Support for canister system
- ⑭ Vacuum hose with angled connection

The universal bracket is suitable for a secretion canister with a diameter of 11.5 - 12.5 cm.

Do not operate the device without a bacterial filter.



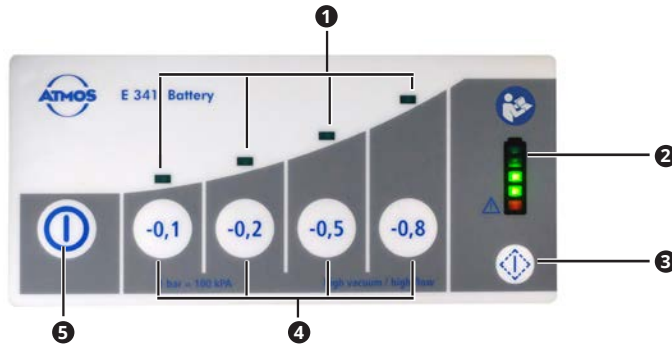



3.1.2 Control panel

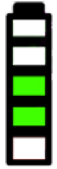

- ❶ LEDs for the display of the actual vacuum
- ❷ Display of the battery status
- ❸ Button battery status
- ❹ Button to select the desired vacuum
- ❺ On/off button

Display of the battery status

The following display values are not valid during battery charging.

					Flashes		Green and red LED flash
> 85 %	60 - 85 %	35 - 60 %	< 15 - 35 %	< 10 - 15 %		< 10 %	

Prior to the battery going dead a signal tone sounds every 5 seconds.

An error is present if all the green LEDs flash simultaneously or all LEDs are flashing. Please observe chapter "7.0 Eliminating errors" on page 50.

3.2 Preparing the device

Prior to first operation, peruse the safety notes in chapter "2.0 Notes for your safety" on page 13.

NOTICE

Damaged pump diaphragms due to cold temperatures during transport.

1. After transport at temperatures below -5 °C : The device must be acclimatized for up to 6 hours before you continue with the next steps.
2. Check the device for any damage in transport.
3. If the device is damaged: Document and report the transport damage. Send the device to ATMOS (see chapter "6.3 Sending in the device" on page 46).
4. If the device is not damaged: place the device on a safe, level surface.
5. Check the charging accessories for any damage.
6. Replace defective charging accessories immediately.
7. The battery must be fully charged, chapter "3.3 Charging the battery" on page 19.
8. Remove the canister system from the support.

9. For DDS canister systems: Prior to first use, clean the secretion canister system and insert a hydrophobic DDS bacterial and viral filter (chapter "5.0 Cleaning and disinfection" on page 36 as well as chapter "3.4 Connection and removal of canister system and hoses" on page 20).
10. Connect the suction hose.

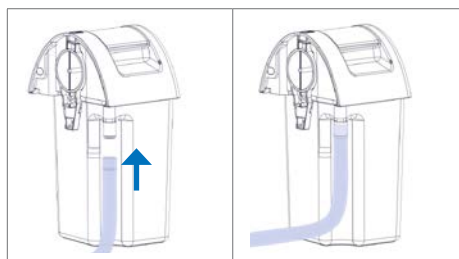

11. Place the canister system upright from above into the support: Chapter "3.4 Connection and removal of canister system and hoses" on page 20.
12. Wind the suction hose onto the hose reel.
13. If you wish to use the device for vacuum mattresses: Check whether a suitable adapter is available for the vacuum mattresses.

3.3 Charging the battery

- ☞ The battery status can be checked by briefly pressing the control button for the battery status.

The battery must be fully charged prior to first use.

NOTICE

Damage to the battery due to deep discharge.

1. Charge the battery at the latest when the bottom green LED of the battery status display flashes.
2. Only use the enclosed power supply and recharging unit 318.0035.0. Other charging accessories must not be used.
3. Please observe the notes in chapter "6.4 Handling of batteries" on page 46.

During battery recharging full suction capacity of the device is still available.

If the battery is fully discharged or defective, the device may be operated via the charging accessories.

- ☞ If the ambient conditions are not adhered to, the charging time for the battery is significantly increased. The charging process will be terminated if the temperature is too high. Therefore, please prevent the device from direct solar radiation and keep it away from radiators.

Environmental conditions during charging: see chapter "10.0 Technical data" on page 57.

Recharging with power supply and recharging unit

1. Connect the device plug from the power supply and recharging unit to the back of



the device ❶.

2. Connect the power cable to the power supply and recharging unit.
3. Plug in the power plug of the power supply and recharging unit to the socket.
 - » The LEDs of the battery status display flash successively.
 - » One LED is continuously illuminated. This indicates the current battery status.
 - » The battery is fully recharged when the top red LED is continuously illuminated.

Recharging via the wall and device support

If you have attached the charging accessories to a wall and device support, then the device will be charged automatically: see chapter "8.1 Wall and device support" on page 54.

1. Attach the device to the wall and device support.
 - » The LEDs of the battery status display flash successively.
 - » One LED is continuously illuminated. This indicates the current battery status.
 - » The battery is fully recharged when the top red LED is continuously illuminated.

3.4 Connection and removal of canister system and hoses

3.4.1 DDS canister system

 **WARNING**

Risk of infection from contaminated hydrophobic DDS bacterial and viral filter and canister lid.

Deadly diseases can be transmitted.

- Never operate the device without a hydrophobic DDS bacterial and viral filter. Always keep at least one spare DDS bacterial and viral filter on hand.
- Wear disposable gloves when changing the hydrophobic DDS bacterial and viral filter.
- Prior to each use check whether the hydrophobic DDS bacterial and viral filter is dry and clean. Replace the hydrophobic DDS bacterial and viral filter with a new hydrophobic DDS bacterial and viral filter if it is discoloured or contaminated or if oversuction has occurred. The hydrophobic DDS bacterial and viral filter must not be dried and reused.
- Replace the hydrophobic DDS bacterial and viral filter when changing the patient. ATMOS recommends: Replace the hydrophobic DDS bacterial and viral filter after 14 days even if there is no patient change.

Removal

1. Remove the suction hose from the hose reel and then from the hose guide
2. Gently unlock the clip **1** of the canister lid from the support of the DDS canister system and lift it upwards:

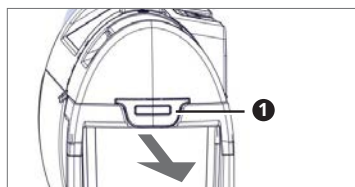

3. Lift the canister system upwards from the support.
4. Place the canister system on a safe and even surface.
5. Remove the suction hose from the secretion canister.
6. Turn the filter holder anti-clockwise by 90°.

☞ The filter holder is difficult to turn because it has to seal the canister lid tightly.

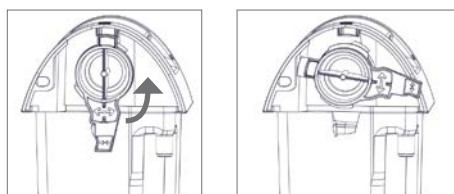

7. Remove the filter holder with the hydrophobic DDS bacterial and viral filter from the canister lid.
8. If necessary: Remove the hydrophobic DDS bacterial and viral filter **7** and the sealing ring **6** from the filter holder **5**.

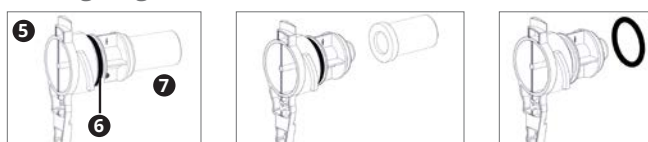

⚠ Risk of infection by overflowing secretion. Deadly diseases can be transmitted.

9. Hold the secretion canister with one hand and pull the canister lid upwards with force.
- » The canister system is open.
10. If required: Slide the inner canister lid out of the external canister lid.



11. If required: Remove the float ball **3** from the float ball compartment **2** of the inner canister lid **1**.

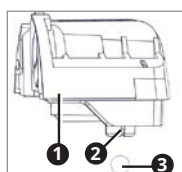

Connection

- ☞ When you pour 50-100 ml water or disinfectant into the secretion canister prior to suctioning, then it is easier to clean.

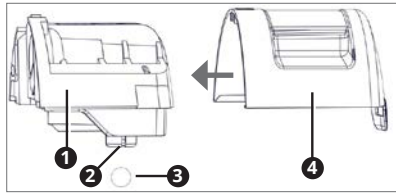

- ❶ Inner canister lid
- ❷ Float ball compartment
- ❸ Float ball
- ❹ Outer canister lid

1. Press the outer canister lid ❹ on the inner canister lid ❶, until it clicks into place.
2. Open the float ball compartment ❷ gently and insert the float ball ❸.
3. Gently press the float ball compartment together.
4. Check whether the float ball moves easily and does not fall out of the float ball compartment.
5. Place the secretion canister on a firm surface.
6. Press the canister lid onto the secretion canister. The canister lid cannot be placed in a wrong position.
7. Press the canister lid tightly with both hands as far as it will go onto the secretion canister.
8. Place the sealing ring ❹ onto the filter holder ❺.

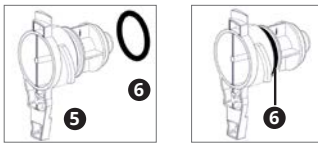

9. Put a new hydrophobic DDS bacterial and viral filter ❽ onto the filter holder ❺.

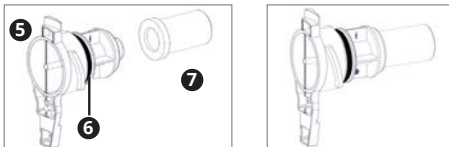

10. Insert the filter holder into the canister lid and turn it clockwise until it clicks into place.

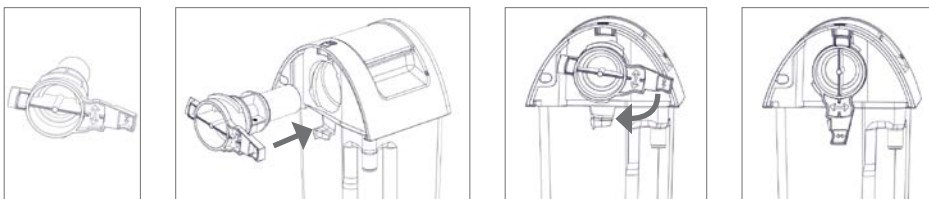

11. Connect the suction hose to the secretion canister system.

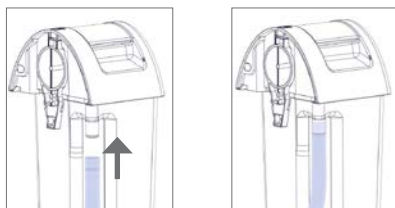

12. Place the canister system upright into the support and at the same time position the suction hose in the hose guide.

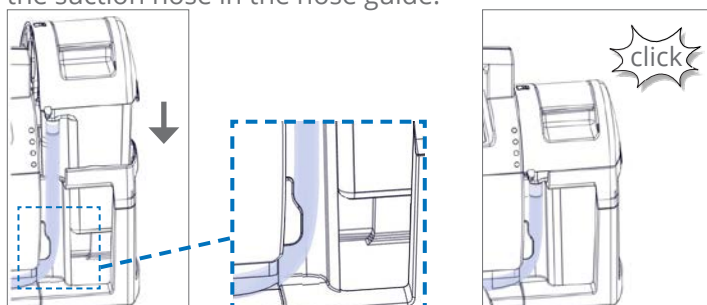

13. Check that the clip ❶ of the canister lid is correctly attached to the support of the canister system.



» The vacuum connection from the pump to the canister system is established.

14. Check whether the hose has a kink. If applicable, remove the kink.

15. Insert the suction hose into the hose guide of the device base.

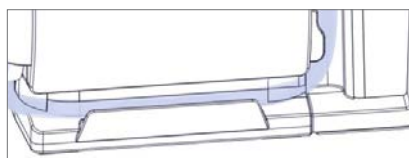

16. Wind the suction hose onto the hose reel.

17. If required: Connect a fingertip to the suction hose.

18. Perform a manual function check: see chapter "6.2.1 Manual function check" on page 44.

3.4.2 Serres® canister system

⚠ WARNING

Risk of infection by contaminated canister system and hoses.

Deadly diseases can be transmitted.

- Only use Serres® suction bags with integrated bacterial filter.
- Only use sterile packaged parts, when the packaging is undamaged.
- Wear disposable gloves.

⚠ WARNING

No vacuum or vacuum is too low because of incorrect connection.

Patient can suffocate.

- Please observe the instructions for use from the manufacturer of the Serres® canister system.

Removal

1. Remove the disposable suction hose from the hose guide.
2. Remove the disposable suction hose and the angle ② from the Serres® suction bag.



3. Close the connection „patient“ at the Serres® suction bag with the green cap ③.
4. Remove the vacuum hose from the Serres® external canister (grey angle ①).
5. Remove the Serres® canister system from the support.
6. If required: Remove the vacuum hose from the device.

Connection

1. Connect the vacuum hose to the device.



2. Place the Serres® external canister upright into the support. The scale must be visible.
3. Insert the Serres® suction bag into the Serres® external canister.
4. Connect the vacuum hose to the Serres® external canister (grey angle ①).



5. Check whether the foil of the Serres® suction bag is fully inserted into the Serres® external canister and the lid tightly fits to the Serres® external canister.
6. Connect the disposable suction hose with the angle ② to the Serres® suction bag.
7. Close the auxiliary air vent of the fingertip and close the front opening with your thumb.
8. Switch on the device so that the pump builds up a vacuum.
 - » The Serres® suction bag develops.
9. Insert the suction hose into the hose guide.

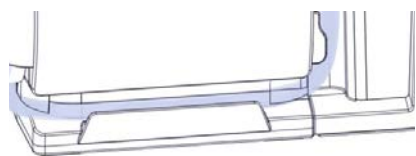

10. Wrap the suction hose onto the hose rewind.
11. Perform a manual function check: see chapter "6.2.1 Manual function check" on page 44.

3.4.3 Medi-Vac® canister system

⚠ WARNING

Risk of infection by contaminated canister system and hoses.

Deadly diseases can be transmitted.

- Only use Medi-Vac® suction bags with integrated bacterial filter.
- Only use sterile packaged parts, when the packaging is undamaged.
- Wear disposable gloves.

⚠ WARNING

No vacuum or vacuum is too low because of incorrect connection.

Patient can suffocate.

- Please observe the instructions for use from the manufacturer of the Medi-Vac® canister system.

Removal

1. Remove the disposable suction hose from the hose guide.
2. Remove the disposable suction hose and the angle ② from the Medi-Vac® suction bag.



3. Close the connection „patient“ at the Medi-Vac® suction bag with the blue cap ③.
4. Remove the red hose ① from the Medi-Vac® suction bag.
5. Close the connection „vacuum“ at the Medi-Vac® suction bag with the blue cap ④.
6. Remove the vacuum hose from the red connection ⑤ of the Medi-Vac® external canister.
7. Remove the Medi-Vac® canister system from the support.
8. If required: Remove the vacuum hose from the device.

Connection

1. Connect the vacuum hose to the device.

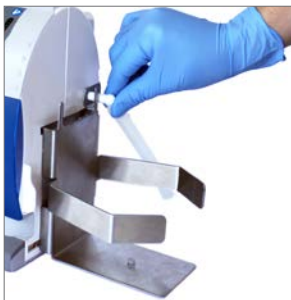

2. Insert the Medi-Vac® suction bag into the Medi-Vac® external canister.
3. Connect the red hose ① to the Medi-Vac® suction bag.
4. Place the Medi-Vac® external canister upright into the support.

5. Connect the vacuum hose to the red connection ③ of the Medi-Vac® external canister.



6. Check whether the lid tightly fits to the Medi-Vac® external canister.
7. Connect the disposable suction hose ② to the Medi-Vac® suction bag.
8. Close the auxiliary air vent of the fingertip and close the front opening with your thumb.
9. Switch on the device so that the pump builds up a vacuum.
 - » The Medi-Vac® suction bag develops.
10. Insert the suction hose into the hose guide.

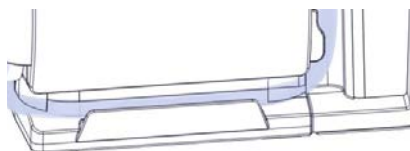

11. Wrap the suction hose onto the hose rewind.
12. Perform a function check: see chapter "6.2 Function check" on page 44.

3.5 Support for canister system

3.5.1 DDS canister system

Removal

1. Remove the canister unlocking.



2. Push the support for the DDS canister system backwards up to the middle and take it out of the guides.



Mounting

1. Attach the support for the DDS canister system in the middle on the right side of the device. The bars at the support must be fitted to the two guides at the device.

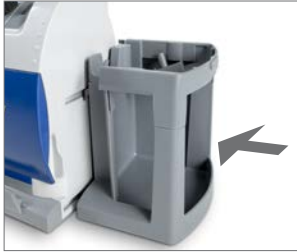

2. Slide the support for the DDS canister system forward until it is flush with the device. The inlet to the pump must be visible.



3. Attach the canister release.



- ☞ The canister unlocking is at the same time the connection angle through which the canister system is connected to the pump.

3.5.2 Serres® canister system

Removal

1. Remove the connection angle.
2. Push the support for the Serres® canister system backwards up to the middle and take it out of the guides.

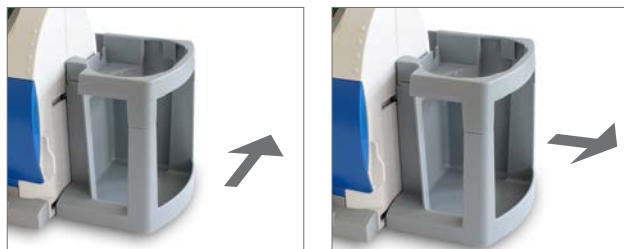

Mounting

1. Attach the support for the Serres® canister system in the middle on the right side of the device. The bars at the support must be fitted to the two guides at the device.

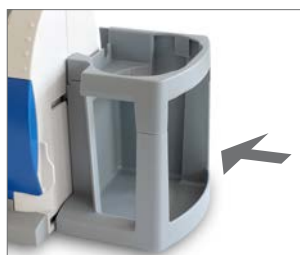

2. Slide the support for the Serres® canister system forward until it is flush with the device. The inlet to the pump must be visible.

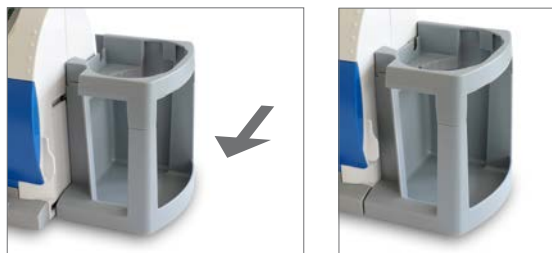

3. Connect the vacuum hose with the connection angle.



3.5.3 Medi-Vac® canister system / Universal bracket

Removal

1. Remove the connection angle.
2. Push the support of the canister system backwards up to the middle and take it out of the guides.

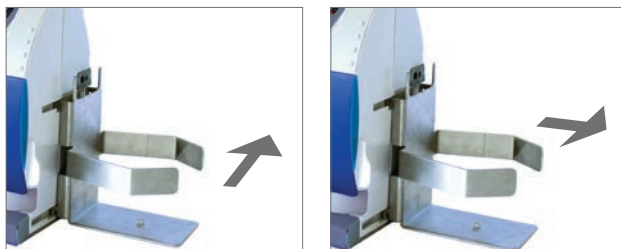

Mounting

1. Attach the support of the canister system in the middle on the right side of the device. The bars at the support must be fitted to the two guides at the device.

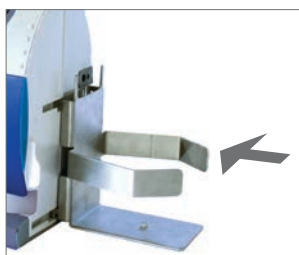

2. Slide the support of the canister system forward until it is flush with the device. The inlet to the pump must be visible.

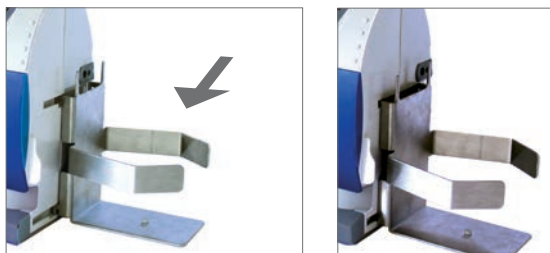

3. Connect the vacuum hose with the connection angle.



- ⊞ The universal bracket is suitable for secretion canisters with a diameter of 11,5 – 12,5 cm.
- ⊞ Do not operate the device without a bacterial filter.

3.6 Hose rewind

Removal

Prerequisite: The hose is unwound.

1. Pull the wings outwards so that the hose rewind can be released.
2. Pull the hose rewind from the device.



Mounting

Prerequisite: Device base and battery compartment cover are attached.

1. Turn the hose rewind so that the opening points upwards.
2. Attach the hose rewind with force to the support on the left side of the device until it clicks into place.



3.7 Device base

Removal

Prerequisite:

The following parts are removed:

- Canister system
 - Support for canister system
 - Hose rewind
 - Battery compartment cover
1. Put the device carefully on the front.
 2. Remove the device base in the following order A - B - C - D:

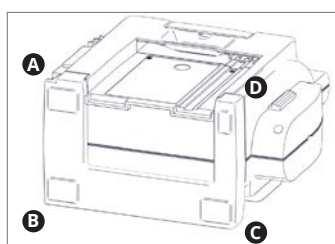

Mounting

⚠ WARNING

Incorrectly mounted device base.

Device moves during the operation.

- Attach the device base with particular care, according to the instructions for use.

Prerequisite:

The following parts are removed:

- Canister system
- Support for canister system
- Hose rewind
- Battery compartment cover

1. Put the device carefully on the front.
2. Take care that the indentations at the device base are fitted to the protruding edges at the device.
3. Attach the device base in the following order D - C - B - A. The arrows show the points at which the device and the device base have to engage with each other.

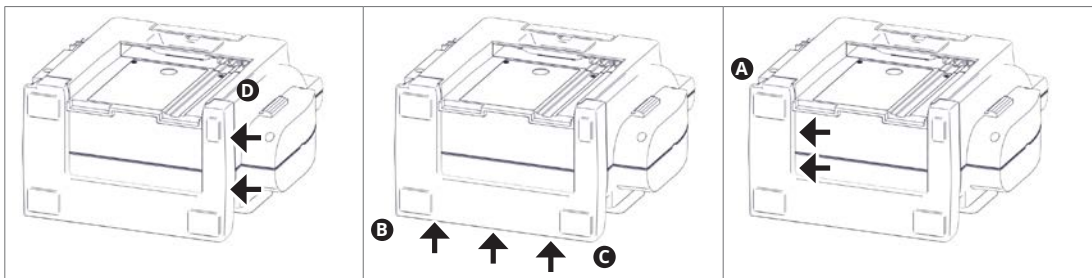

4. Firmly press on all sides again.
5. Afterwards the following parts can be mounted:
 - Battery compartment cover (chapter "6.5 Battery exchange" on page 47)
 - Hose rewind (chapter "3.6 Hose rewind" on page 31)
 - Support for canister system (chapter "3.5 Support for canister system" on page 27)
 - Canister system (chapter "3.4 Connection and removal of canister system and hoses" on page 20).

4.0 Operation

⚠ WARNING

Risk of infection by lack of hygiene or damaged components.

Deadly diseases can be transmitted.

- Please use new consumables and new disposable canister systems or reprocessed DDS canister systems for each patient.
- Prior to each use, please check whether hoses or canister systems are damaged. Replace any damaged parts.

⚠ WARNING

Electric shock from damaged equipment.

Cardiac arrhythmias may be caused.

- Prior to each use, please check whether the device and the recharging accessories are damaged.
- Replace any damaged parts immediately.
- Do not use the device if it is damaged.

Environmental conditions for operation: see chapter “10.0 Technical data” on page 57.

4.1 Switch on the device

- ☞ The device should only be left on as long as you need it. This way you can increase the battery life.
1. Push the on /off button to switch on the device.
 - » The pump starts. The vacuum is set which was selected prior to switch off.
 - » All LEDs on the control panel light up for about 1 second.
 - » The on/off button is illuminated as long as the device is switched on.

4.2 Switch off the device

1. Switch off the device by pressing the on/off button for at least 1 second.

4.3 Vacuum adjustment

⚠ WARNING

Vacuum is too high.

Patient may be seriously injured.

- Observe the valid guidelines.
 - Please select the vacuum according to the patient and the application.
 - Using the device on children requires a lower vacuum setting. Observe the instructions issued by the attending physician.
1. Push the on /off button to switch on the device.
 - » The pump starts. The vacuum is set which was selected prior to switch off.
 2. Push the button for the required vacuum.
 - » The green LED above the selected button flashes.

4.4 Suction

⚠ WARNING

Device failure, if the period of continuous operation is too long.

Patient can suffocate.

- Make sure not to use the device in continuous operation for more than 60 minutes. Otherwise the pump shuts off automatically. In this case let the device cool down for about 2 hours.
- Check the status of the battery regularly while you operate the device.

⚠ WARNING

Risk of infection.

Deadly diseases can be transmitted.

- Always wear disposable gloves during suction.

⚠ CAUTION

Risk of injury due to inappropriate material or untrained users.

Injuries in the oral cavity and pharynx of the patient.

- Suction may only be carried out by persons who were medically trained, and were trained in the medical suction.
- Suction particularly carefully in the tracheal area.
- Patient may be seriously injured if the set vacuum is too high. Please select the vacuum according to the patient and the application.
- Use a suction catheter for tracheal or nasopharyngeal suction.
- If you suction viscous food ingredients in the oral cavity, use the suction hose without the suction catheter.

Connect the suction catheter

1. Remove the suction hose from the hose rewind.

If you suck viscous food ingredients in the oral cavity:

2. Use the suction hose without a suction catheter.

For tracheal or nasopharyngeal suction:

2. Please choose a suction catheter in the appropriate size.

3. Connect the suction hose ❶ and the suction catheter ❸ using a fingertip ❹:

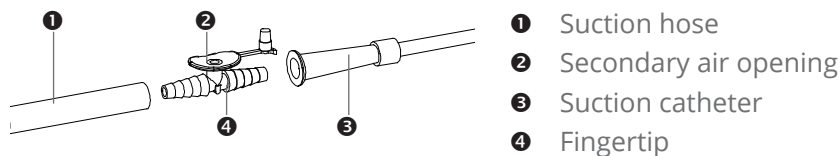

Connect the special suction instruments

1. Observe the manufacturer's instructions for use for the suction instruments.

Suction

⚠ CAUTION

Adherence by careless suction.

Injuries in the oral cavity and pharynx of the patient.

- Briefly open the auxiliary air vent ②, if the suction catheter adheres to the tissue.
 - Suck particularly careful in the tracheal area.
1. Push the on /off button to switch on the device.
- » The pump starts. The vacuum is set which was selected prior to switch off.

⚠ CAUTION

Patient may be seriously injured if the set vacuum is too high.

2. Please select the vacuum according to the patient and the application. Push the button for the required vacuum.
- » The green LED above the selected button flashes.
- ☞ As long as the auxiliary air vent is opened, the device does not suck.
1. Open the auxiliary air vent before inserting the suction catheter.
 2. Apply the suction catheter in such a way as you were taught.
 3. Close the auxiliary air vent, so that the device sucks.

⚠ CAUTION

Suffocation is possible due to full canister system.

4. Pay attention to the filling level of the canister system.
5. Empty the secretion canister or change the suction bag once it is half full. As soon as the canister system is too full, the float ball seals the intake area. You can then no longer suck with the device.

Make sure that the hose is not kinked during suction. Otherwise the suction capacity applied on the patient is too low.

- ☞ If you want to interrupt the suction briefly, you can clamp the suction hose into the opening of the hose reel.



If secretion has penetrated into the device, please observe chapter “5.6 Oversuction” on page 43.

After use

1. Switch off the device by pressing the on/off button for at least 1 second.
2. Clean the device after each use: see chapter “5.0 Cleaning and disinfection” on page 36.
3. Perform a function check after each cleaning: see chapter “6.2 Function check” on page 44.

5.0 Cleaning and disinfection

We recommend you to document any maintenance work and also any exchange of parts.

⚠ WARNING

Risk of infection by secretion on the device, accessories and consumables.

Deadly diseases can be transmitted.

- Always wear disposable gloves during any cleaning.
- Clean the device after every use:
- Clean and disinfect the device according to the instructions for use.
- The device must be reprocessed professionally, if secretion has penetrated into the device. Observe chapter "5.6 Oversuction" on page 43.

5.1 Prepare for cleaning

1. Switch off the device.
2. Remove the recharging accessories from the device.
3. Remove the canister system from the device: Chapter "3.4 Connection and removal of canister system and hoses" on page 20.

⚠ WARNING

Risk of infection due to secretion spilling over. Deadly diseases can be transmitted.

4. Carefully remove the canister lid / the suction bag.
5. Dispose of the secretion / the suction bag. Please observe the notes in chapter "9.0 Disposal" on page 56.
6. Dispose of all disposables (e.g. suction catheter, fingertip, single-use suction hose).
If you are using the DDS canister system: Dispose of the hydrophobic DDS bacterial and viral filter.
7. Remove the hose rewind.
8. Remove the support for the canister system.

5.2 Cleaning

Please observe the instructions for use provided by the disinfectant manufacturers. Pay particular attention to the information regarding the concentration of the disinfectants and the material compatibility.

Some disinfectants may stain the parts of the canister lid and silicone hoses. Parts can also stain by autoclaving. However, this has no influence on the properties of the materials.

Please only use disinfectants, which are recommended by ATMOS (chapter "5.4 Recommended disinfectants" on page 39). The use of other disinfectants may damage the device or the canister system.

DDS canister system

Number of reprocessing cycles: max. 50.

1. Disassemble canister lid and filter holder into their individual parts. Chapter "3.4 Connection and removal of canister system and hoses" on page 20.

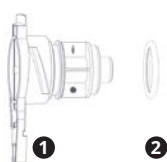

- ❶ Filter holder
- ❷ Sealing ring

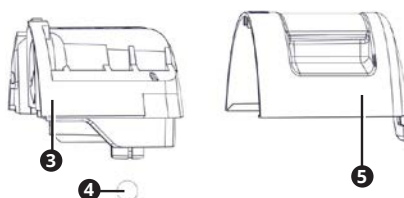

- ❸ Inner canister lid
- ❹ Float ball
- ❺ External canister lid

2. Rinse the following parts of the DDS canister system with clear water:
 - Secretion canister
 - Inner canister lid
 - Outer canister lid
 - Float ball
 - Filter holder
 - Sealing ring
 - Suction hose
 - Support for canister system
 3. Clean the mentioned parts with a brush or a cloth.
 4. Disinfect the mentioned parts with a disinfectant which is recommended by ATMOS.
 5. Let the individual parts of the canister lid and the filter holder dry.
- As soon as the individual parts are dry:
6. Insert a new hydrophobic DDS bacterial and viral filter.
 7. Reassemble the individual parts of the canister lid and the filter holder.

Serres®, Medi-Vac® canister system, other canister systems

- Please observe the directions in the instructions for use of the canister system.
- Do not operate the device without a bacterial filter. The hydrophobic bacterial and viral filter (REF 443.0738.0) must be used with a secretion canister system which has no integrated bacterial filter.

Vacuum hose

After every suction process:

1. Rinse the vacuum hose with clear water for at least 10 seconds.
It must be exchanged after each patient or at least once a day:
2. Disinfect the vacuum hose with a disinfectant for the accessories recommended by ATMOS.

Device surface

⚠ WARNING

Electric shock by liquid in the device.

- Disconnect the device from the mains power supply prior to cleaning.
 - Do not rinse the device under running water and do not immerse it into any liquids.
 - Make sure that the cleaning cloth is only damp and not wet.
 - Do not autoclave the device.
 - Do not immerse the device in disinfectant solution.
1. Clean the entire surface of the device and the hose rewind with a damp cloth.
 2. Disinfect the entire surface of the device and the hose rewind with a surface disinfectant.

Power supply and recharging unit

⚠ WARNING

Electric shock by liquid in the power supply.

- Disconnect the power supply and recharging unit from the mains power supply prior to cleaning.
 - Do not rinse the power supply and recharging unit under running water and do not immerse it into any liquids.
 - Make sure that the cleaning cloth is only damp and not wet.
 - Do not autoclave the power supply and recharging unit, do not sterilize it and do not thermally disinfect it.
 - Do not immerse the power supply and recharging unit in disinfectant solution.
1. Clean the power supply and recharging unit with a damp cloth. You can use a mild detergent.
 2. Disinfect the power supply and recharging unit with a surface disinfectant. Recommended: Terralin® Protect.

Wall and device support

1. Clean the wall and device support with a damp cloth.
2. Disinfect the wall and device support with a surface disinfectant.

5.3 After cleaning

⚠ WARNING

Risk of injury to user and patient due to a damaged device.

1. Check after each cleaning, whether the device is obviously damaged. In case the device is damaged, please send it in to ATMOS.
2. Perform a function check: see chapter "6.2 Function check" on page 44.
3. Prepare the device for the next use.

5.4 Recommended disinfectants

If you are using aldehyde and amine-containing disinfectants on the same object, this may cause discolouration.

5.4.1 Instrument disinfection

Disinfectant	Ingredients	in 100 g	Manufacturer
Mucocit®-T	didecyldimethylammonium chloride alkyl propylene diamin-1.5-bis guanidinium acetate bis(aminopropyl)laurylamine laurylpropylen diamine non-ionic surfactants	3.9 g 4.5 g 2 g 2.8 g	Merz Dental, Lütjenburg
Gigasept® FF (new) (Application concentrate)	succinaldehyde dimethoxytetrahydrofuran anionic and non-ionic surfactants, perfumes, methylisothiazolinone	11.9 g 3.2 g	Schülke & Mayr, Norderstedt
Sekusept® PLUS (Application concentrate)	glucoprotamin	25 g	Ecolab, Düsseldorf

5.4.2 Surface disinfection

Coated surfaces

Disinfectant	Ingredients	(in 100 g)	Manufacturer
Green & Clean SK	Di alkyl dimethyl ammonium chloride Alkyl dimethyl ethyl benzyl ammonium chloride Alkyl dimethyl benzyl ammonium chloride	< 1 g < 1 g < 1 g	Metasys, Rum (Austria)
Dismozon® plus (Granulate)	magnesium monoperoxyphthalate hexahydrate	95.8 g	Bode Chemie, Hamburg
Kohrsolin® FF (Application concentrate)	glutaral benzyl-C12-C18-alkyldimethyl-ammonium chlorides didecyldimethylammonium chloride	5 g 3 g 3 g	Bode Chemie, Hamburg
Kohrsolin® extra (Application concentrate)	(ethylenedioxy)dimethanol glutaral didecyldimethylammonium chloride	14.1 g 5 g 8 g	Bode Chemie, Hamburg
Perform®	Potassium-bis(peroxymonosulfate)-bis(sulfate)	45 g	Schülke & Mayr, Norderstedt
Terralin® Protect (Application concentrate)	benzyl-C12-16 alkyldimethyl-, chloride 2-phenoxyethanol aminoalkylglycine non-ionic surfactants, perfumes	22 g 17 g 0.9 g	Schülke & Mayr, Norderstedt

Other surfaces

Disinfectant	Ingredients(in 100 g)	(in 100 g)	Manufacturer
Dismozon® plus (Granulate)	magnesium monoperoxyphthalate hexahydrate	95.8 g	Bode Chemie, Hamburg
Kohrsolin® FF (Application concentrate)	glutaral benzyl-C12-18-alkyldimethyl-ammonium chlorides didecyldimethylammonium chloride	5 g 3 g 3 g	Bode Chemie, Hamburg
Kohrsolin® extra (Application concentrate)	(ethylenedioxy)dimethanol glutaral didecyldimethylammonium chloride	14.1 g 5 g 8 g	Bode Chemie, Hamburg
Mikrobac® forte (Application concentrate)	benzyl-C12-18-alkyldimethyl-ammonium chlorides N-(3-aminopropyl)-N-dodecylpropane-1,3-diamine	19.9 g 5 g	Bode Chemie, Hamburg
Perform®	Potassium-bis(peroxymonosulfate)-bis(sulfate)	45 g	Schülke & Mayr, Norderstedt

Disinfectant	Ingredients(in 100 g)	(in 100 g)	Manufacturer
Terralin® Protect (Application concentrate) Suitable for power supply and recharging unit.	benzyl-C12-16 alkyldimethyl-, chloride 2-phenoxyethanol aminoalkylglycine non-ionic surfactants, perfumes	22 g 17 g 0.9 g	Schülke & Mayr, Norderstedt
SaniCloth® Active	didecyldimethylammonium chloride	< 1 g	Ecolab, Düsseldorf
Incidin® Active	peracetic acid	< 1 g	Ecolab, Düsseldorf
Mikrozid® Sensitive Wipes	benzyl-C12-16 alkyldimethyl-, chloride; didecyldimethylammonium chloride benzyl-C12-14-alkyl [(ethylphenyl)methyl] dimethyl-, chlorides	0.26 g 0.26 g 0.26 g	Schülke & Mayr, Norderstedt
Gigasept® pearls Suitable for DDS secretion canister	sodium percarbonate tetraacetythylenediamine	43 g 22 g	Schülke & Mayr, Norderstedt

5.4.3 Pre-cleaning

1. Disconnect the device from the mains power supply.
2. Clean the surface evenly with a suitable cloth and clear water. Pay particular attention to hard-to-reach areas.
3. Remove the suction hose and rinse it out with water over a sink.
 - » No more soiling is visible.

5.4.4 Wipe cleaning

1. Disconnect the device from the mains power supply.
2. Clean the surface evenly with a suitable cloth and suitable cleaning agent; see chapter "5.2 Cleaning" on page 36. Pay particular attention to hard-to-reach areas.
 - » No more soiling is visible.

5.4.5 Wipe disinfection

1. Disinfect the surface evenly with a suitable cloth and suitable disinfectant. Pay particular attention to hard-to-reach areas. Do not use spray disinfectant directly on the device.
2. Wait for the exposure time to work.
3. Allow the surface to dry.

5.5 Reprocessing the accessories

5.5.1 Overview

Accessory	Disposable product	Max. reprocessing cycles	After each application	After each patient	Daily	Weekly	Every 14 days	Monthly	Pre-treating	Pre-cleaning	Manual cleaning and disinfection	Mechanical cleaning and disinfection	Sterilising
Accessories													
Device base				X							X		
Hose reel				X							X		

Accessory	Disposable product	Max. reprocessing cycles	After each application	After each patient	Daily	Weekly	Every 14 days	Monthly	Pre-treating	Pre-cleaning	Manual cleaning and disinfection	Mechanical cleaning and disinfection	Sterilising
Wall and device support				X							X		
Secretion canister system													
DDS secretion canister		60	X						X	X		X	X
DDS external canister lid		60	X						X	X		X	X
DDS inner canister lid		60	X						X	X		X	X
Float ball		60	X						X	X		X	X
Filter holder		60	X						X	X		X	X
Sealing ring		60	X								X		
Hydrophobic DDS bacterial and viral filter ¹	X												
Support for DDS canister system		50		X					X	X		X	X
Support for Serres® canister system		50		X					X	X		X	X
Support for Medi-Vac® canister system		50		X					X	X		X	X
Hoses													
Suction hose		60	X						X	X		X	X
Vacuum hose complete		60	X						X	X		X	X

¹ Replace the hydrophobic DDS bacterial and viral filter if it is discoloured, soiled, or if oversuction has occurred; see chapter “3.4.1 DDS canister system” on page 20.

5.5.2 Secretion canister system

Characteristics

The accessories have the following hard-to-reach areas:

- DDS external canister lid
- DDS inner canister lid
- Support for DDS canister system
- Support for Serres® canister system
- Vacuum hose complete

Take particular care when reprocessing hard-to-reach areas.

Pre-treatment at the site of use <ul style="list-style-type: none"> • Flushing: 60 s • Rinsing: 60 s 	<ul style="list-style-type: none"> • Empty the secretion canister • Clean the accessories under cold, running water. • Rinse the hollow spaces and lumina of the accessories thoroughly under running water. <p>No more residue is visible.</p>
Collecting and transporting	<ul style="list-style-type: none"> • Label any damaged accessories. • Place the accessories in a secretion canister. • Transport the secretion canister to the reprocessing location.
Dismantling	<ul style="list-style-type: none"> • See chapter ‘5.2 Preparing / completing reprocessing’ • Dispose of disposable products

<p>Pre-cleaning</p> <ul style="list-style-type: none"> • Flushing: 1x / 30s • Rinsing: 60 s <p>Brush: Round brush Size: 7 mm, material: nylon Brush: Round brush Size: 11 mm, material: nylon Brush: Round brush Size: 15 mm, material: nylon Brush: Square Size: 40 x 10 mm, material: nylon, characteristics: with angled head</p>	<ul style="list-style-type: none"> • Make the following hollow spaces accessible: <ul style="list-style-type: none"> - double hose connector - canister lid • Make the following lumina accessible: <ul style="list-style-type: none"> - double hose connector • Thoroughly clean the accessories evenly with a suitable brush under running water • Rinse the hollow spaces and lumina of the accessories thoroughly under running water.
<p>Mechanical cleaning and disinfection</p> <p>Pre-wash: 1 min Clean: 5 min, 50°C / 122°F Neutralise: 2 min Intermediate rinse: 1 min Disinfect: 5 min, 93°C / 199°F Drying: 12 min, 110°C / 230°F</p>	<ul style="list-style-type: none"> • Secure the accessories on a suitable load carrier. • Clean and disinfect using a suitable program: <ul style="list-style-type: none"> - rinse with cold water - clean with cleaning agents - neutralise with neutralising agents - intermediate rinse with softened, cold water - disinfect with demineralised water - dry • Washer-disinfect: according to EN ISO 15883-1 • Programme: Miele Vario TD
<p>Checking and maintaining</p>	<ul style="list-style-type: none"> • Check the success of reprocessing with a suitable light magnifier. They must be free of particles and organic material. • If reprocessing was unsuccessful, reprocess the accessories again. • Dispose of damaged accessories or have them repaired.
<p>Assembly</p>	<ul style="list-style-type: none"> • Not necessary.
<p>Function check</p>	<ul style="list-style-type: none"> • Not necessary.
<p>Packaging</p>	<ul style="list-style-type: none"> • Label the accessories. • Pack the accessories with a packaging system according to DIN EN ISO 11607.
<p>Sterilising</p> <p>Pre-fractionated vacuum: 3x Temperature: 134°C / 273°F Time: 5 min Dry: 10 min</p>	<ul style="list-style-type: none"> • Sterilise the accessories using a suitable procedure: <ul style="list-style-type: none"> - steam sterilisation / autoclaving • Steriliser: according to EN 285
<p>Storage</p>	<ul style="list-style-type: none"> • Observe the environmental conditions; see chapter "10.0 Technical data" on page 57.

5.5.3 Hoses

<p>Pre-treatment at the site of use</p>	<ul style="list-style-type: none"> • Clean the accessories under cold, running water. • Thoroughly rinse the hollow spaces of the accessories with running water. <p>No more residue is visible.</p>
<p>Collecting and transporting</p>	<ul style="list-style-type: none"> • Label any damaged accessories. • Place the accessories in a secretion canister. • Close the secretion canister. • Transport the secretion canister to the reprocessing location.

Pre-cleaning	<ul style="list-style-type: none"> • Clean the accessories evenly under running water. • Rinse the lumina of the accessories thoroughly under running water.
Dismantling	Not necessary.
Mechanical cleaning and disinfection Pre-wash: 1 min Clean: 5 min, 55 °C / 131 °F Neutralise: 2 min Intermediate rinse: 1 min Disinfect: 5 min, 93°C / 199°F Drying: 12 min, 110°C / 230°F	<ul style="list-style-type: none"> • Secure the accessories on a suitable load carrier. • Clean and disinfect using a suitable program: <ul style="list-style-type: none"> – rinse with cold water – clean with cleaning agents – neutralise with cold water – intermediate rinse with softened, cold water – disinfect with demineralised water – dry • Washer-disinfector: according to EN ISO 15883-1 • Adapter: Miele E366/E446 • Programme: Miele Vario TD
Checking and maintaining	<ul style="list-style-type: none"> • Check the success of reprocessing with a suitable light magnifier. • If reprocessing was unsuccessful, reprocess the accessories again. • Dispose of damaged accessories or have them repaired.
Assembly	Not necessary.
Function check	Not necessary.
Packaging	<ul style="list-style-type: none"> • Label the accessories. • Pack the accessories with a packaging system according to DIN EN ISO 11607.
Sterilising Pre-fractionated vacuum: 3x Temperature: 134°C / 273°F Time: 5 min Dry: 10 min	<ul style="list-style-type: none"> • Sterilise the accessories using a suitable procedure: <ul style="list-style-type: none"> - steam sterilisation / autoclaving Steriliser: in accordance with EN 285.
Storage	<ul style="list-style-type: none"> • Observe the environmental conditions; see chapter "10.0 Technical data" on page 57.

5.6 Oversuction

If you use the ATMOS E 341 Battery according to instructions, with hydrophobic DDS bacterial and viral filter and float ball, the device cannot be oversucked during normal use. Nevertheless, should secretion penetrate into the interior of the device, the device is oversucked.

This can happen, for example, if no DDS bacterial and viral filter is used and the device tips over.

Reduced suction capacity is an indication for an oversucked device. If you suspect that your device might be oversucked, proceed as follows:

WARNING

Risk of infection by secretion on and within the device.

Deadly diseases can be transmitted.

- Always wear disposable gloves when touching the oversucked device.
- Clean and disinfect the device.
- Send in the device to ATMOS or an authorised ATMOS service partner; see chapter "6.3 Sending in the device" on page 46.

6.0 Maintenance and service

Maintenance, repairs and periodic tests may only be carried out by persons who have the appropriate technical knowledge and are familiar with the product. To carry out these measures the person must have the necessary test devices and original spare parts.

ATMOS recommends: work should be carried out by an authorised ATMOS service partner. This ensures that repairs and testing are carried out professionally, original spare parts are used and warranty claims remain unaffected.

6.1 Periodic tests

Please comply with the country-specific guidelines regarding regular testing especially for the electrical safety.

ATMOS recommends a test every 24 months.

6.2 Function check

Perform a function check:

- prior to each use
- after each use or cleaning
- every 4 weeks in case the device is not used
- after every maintenance work, service or repair

6.2.1 Manual function check

1. Please check whether the following parts are damaged or torn:
 - all hoses
 - Canister system
2. In case parts are visibly damaged: Please replace them.
3. Switch on the device.
4. Check whether all LEDs are illuminated.
5. Check the battery status.
6. Connect a fingertip to the suction hose and close the secondary air opening.
7. Close the front opening of the fingertip with your thumb.
8. Select the vacuum -0.5 bar.
9. Please check whether the device reaches the vacuum after approx. 20 seconds: The pump switches off and the green LED above the -0.5 bar button is illuminated continuously.
10. In case the device does not reach the vacuum within 20 seconds, please check the device for any possible sources of error and remedy them: see chapter "7.0 Eliminating errors" on page 50.
11. You may now use the device or switch it off.

6.2.2 Automatic function check

Termination

1. Press the control button battery status.
- » The device switches off.

Perform a function check

The automatic function control checks successively the following functions:













- Remaining operating hours
- Battery service life
- Tightness (duration: approx. 10 seconds)

The display of battery status shows the results in quick succession. Therefore, first read this section completely.

Between the individual tests only the red LED is illuminated and a signal tone sounds. If two signal tones are sounded in direct succession then the previous test has failed.

1. Connect a fingertip to the suction hose.
2. Close the auxiliary air vent of the fingertip and close the front opening with your thumb.
3. Press the control button for the battery status for approx. 3 seconds.
- » The function check starts as soon as all LEDs are illuminated. The first result is shown immediately.
4. Check the results by means of the battery status indication.
5. The fingertip may only be opened when all LEDs are off. The function check is completed.

Result

Remaining operating hours				
1.  > 750 h	2.  > 500 h	3.  > 250 h	4.  < 250 h	Short signal tone: < 50 h 1. Please contact your service.
Remaining battery capacity				
1.  100 %	2.  70 %	3.  40 %	4.  20 %	Short signal tone: < 10 % 1. Exchange the battery.
Tightness				
1.  - 0.5 bar	2.  - 0.4 bar	3.  - 0.3 bar	4.  - 0.2 bar	Short signal tone: System has a leakage. 1. See chapter "7.0 Eliminating errors" on page 50.

6.3 Sending in the device

1. Remove and properly dispose of consumables.
 2. Clean and disinfect the products and accessories according to the instructions for use.
 3. Place used accessories with the device.
 4. Fill in the form QD 434 "Delivery complaint / return shipment" and the respective **Decontamination certificate**.
- ☞ This form is enclosed with each delivery and can be found at www.atmosmed.com.
5. The device must be well padded and packed in suitable packaging.
 6. Place the form QD 434 "Delivery complaint / return shipment" and the respective decontamination certificate in an envelope.
 7. Affix the envelope to the outside of the package.
 8. Send the product to ATMOS or to your dealer.

6.4 Handling of batteries

Batteries are wearing parts and therefore excluded from the general warranty.

There is a function guarantee of 6 months.

Please observe the following notes in order to reach the maximum service life of your battery:

- Exclusively use the lithium-ion battery from ATMOS MedizinTechnik.
- Prior to first use the battery must be fully charged.
- Batteries are run-down after approx. 500 charging cycles.

6.4.1 Battery

- Protect the batteries from direct solar radiation and keep them away from radiators.
- Store the battery in a dry environment.
- The battery must be stored within the specified storage conditions (see chapter "10.0 Technical data" on page 57).
- To achieve optimum service life, the battery should not be discharged below the recommended minimum battery voltage (10 V), even during storage.
- When delivered, the battery has a maximum charge of 30%.
- We recommend checking the battery every 6 months and recharging it to 30%.

NOTICE

- The battery polarity must be observed.
- The battery terminals must not be short-circuited.
- The battery must not be subjected to strong shocks or mechanical stress.
- The battery must not be used in potentially explosive environments.

6.4.2 Device with built-in battery

- Always store the device with the battery fully charged.
- Fully charge the battery built into the device every 6 months, even if you are not using the device.
- Exchange the battery when the remaining battery service life noticeably decreases.

6.5 Battery exchange

NOTICE

Damage to the electronics due to the use of a third-party battery.

- Exclusively use the lithium-ion battery from ATMOS MedizinTechnik. This battery is included in the scope of delivery and is available at ATMOS. The warranty claim shall not be applicable if non-original spare parts are used.

Prerequisite: The support for the canister system is removed.

1. Switch off the device.
2. Disconnect the device from the power supply.
3. Remove the hose reel: chapter "3.6 Hose rewind" on page 31.
4. Place the device on its back with the control panel facing upwards.
5. Press the battery compartment cover **1** from right a little towards the left.



6. Lift the battery compartment cover slightly and remove it from the upper guide.

NOTICE

Material damage if the release button on the battery connector is not pressed!

- Removing the battery without pressing the **release button on the underside** of the battery connector can damage the electronics of the device.
- Always unlock the battery connector with the release button before removing it.
- ❗ The detent **2** could break off due to the incorrect removal of the cable.

7. Remove the cable from the device by pressing the detent **2** of the plug against the plug and simultaneously pull the plug.

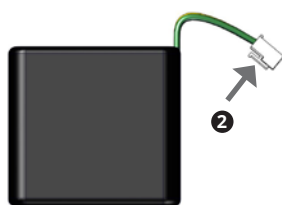
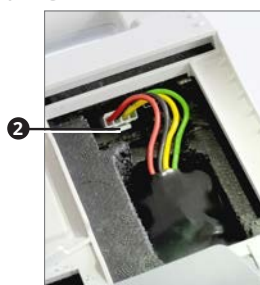

NOTICE

Device damage due to faulty or incorrect connection of the battery connector!

- If the battery connector is defective or is connected incorrectly, the device cannot be used in battery mode. The device cannot be recharged, switched on or off.

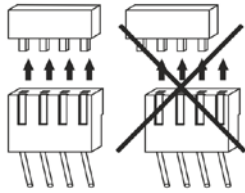

- Check the connection of the battery connector.
 - Disconnect the faulty connection from the battery connector and the device.
 - Connect the battery connector to the device as shown in the figure.
8. Remove the battery in the upwards direction.
 9. Insert the new battery. Please observe that the shape of the battery compartment corresponds to the shape of the battery and the symbol  indicates towards the socket in the battery compartment.
 10. Plug in the connector of the battery cable to the socket in the battery compartment. Please note: All pins must be connected to the plug.
 11. Stow the cables in the battery compartment so that they cannot be damaged by the battery compartment cover.
 12. Insert the battery compartment cover in the upper rail.
 13. Slide the battery compartment cover to the right until it stops.
 14. Press down the battery compartment cover.
 15. Slide the battery compartment cover completely to the right.
 16. Attach the hose reel: Chapter "3.6 Hose rewind" on page 31.
 17. Affix the support for the canister system: Chapter "3.4 Connection and removal of canister system and hoses" on page 20.
 18. Perform a function check.

6.6 Exchange release button

- ☞ There are 2 springs under the release button. Pay attention that they are not misplaced.
1. Place the screwdriver in the middle of the release button and lift the release button up.

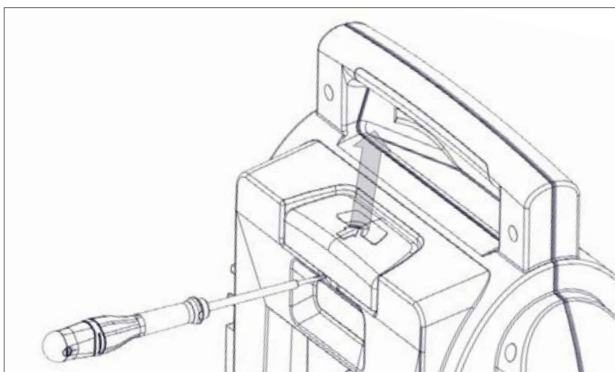

2. Replace with a new release button. Pay attention that the two springs are positioned in the guide of the release button.

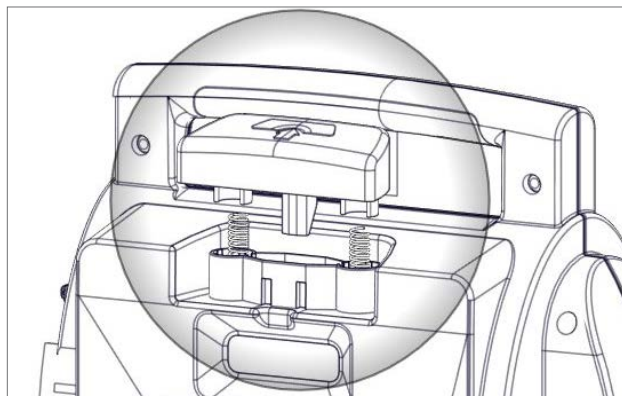

3. Press the release button downwards until it engages.

7.0 Eliminating errors

The ATMOS E 341 Battery was subjected to thorough quality control in the factory. Nevertheless, if a problem may occur you can possibly solve it yourself.

Recharging and battery status

Error indication	Possible cause	Remedy
Device cannot be recharged.	The plug from the charging accessories is poorly fitted.	Check the connection to the mains supply.
	Charging accessories are defective.	Exchange charging accessories.
	Battery is not connected properly.	Check the plug connections in the battery compartment.
	Battery temperature too high or too low.	After prolonged use: Let the device cool down. Extreme ambient temperature: If necessary, move the device to a cooler or warmer location.
	Deep discharge of the battery.	Exchange the battery.
	Defective electronics.	Send in the device for repair.
LED on the power supply and recharging unit is not illuminated.	Defective power supply and recharging unit.	Exchange the power supply and recharging unit.
	The power plug is poorly fitted.	Check the connection to the mains supply.
When recharging the battery 100 % cannot be achieved. The charging time can take up to 3 hours.	Battery service life is exhausted or the battery is defective.	Exchange the battery.
	Wrong charging accessories.	Only use the provided charging accessories or an original spare part.
The bottom green and the red LED on the display of battery status flashes and a signal tone sounds every 5 s.	Battery is almost completely discharged.	Recharge the battery.
During switch on: All LEDs of the display of battery status flash for 5 s; a signal tone sounds.	Remaining battery level is low.	Perform a function check. Exchange the battery.
All the green LEDs on the display of battery status flash permanently.	A non-ATMOS battery is used.	Only use the provided battery or an original spare part.

Error indication	Possible cause	Remedy
All the LEDs on the display of battery status flash permanently.	Battery is not inserted.	Insert the battery.
	Battery is not connected properly.	Check the plug connections in the battery compartment.
	Defective battery.	Exchange the battery.
	Defective electronics.	Send in the device for repair.
Battery compartment cover cannot be closed.	Battery is not fitted correctly.	Fit the battery correctly.
	Battery compartment cover is installed incorrectly.	Mount the battery compartment cover correctly according to the instructions for use.

On and Off switching

Error indication	Possible cause	Remedy
Device cannot be switched on or off.	Battery is discharged.	Recharge the battery.
	Battery is not connected properly.	Check the plug connections in the battery compartment.
	The plug from the charging accessories is poorly fitted.	Check the connection to the mains supply.
	Defective electronics.	Send in the device for repair.
During switch on: Battery LEDs blink once, but the device does not start.	Device was stored outside the operating temperature (battery is in standby).	Switch on the device again.
During switch on: the red LED of the display of battery status flashes for 5 s, a signal tone sounds.	Device is not ready.	Perform a function check. Send in the device for repair.
Pump does not start up.	Vacuum is already built up.	Do not switch on the device if the vacuum is already built up.
Device switches off after 60 min.	Self-protection of the device.	Let the device cool down for approx. 2 hours.
Device switches off after < 60 min.	Battery is discharged.	Recharge the battery.
	Battery temperature is too high.	Let the device cool down or select a lower vacuum.

Vacuum and suction capacity

Error indication	Possible cause	Remedy
Vacuum is not built up or cannot be reached.	Battery is discharged or defective.	Recharge or exchange the battery.
	Leakages at the hoses or the canister system.	Check canister lid and hoses on tight fit. DDS canister system: Firmly insert the hydrophobic DDS bacterial and viral filter and check the sealing ring and filter holder.
	Fingertip is not closed.	Close both openings of the fingertip.
	Liquid has penetrated the device.	Send in the device for repair.
	Pump is defective or the device has a leak.	Send in the device for repair.
	Low ambient pressure (e.g. high altitude).	Not possible.
Low suction capacity although the vacuum has been reached.	Hydrophobic DDS bacterial and viral filter is blocked.	Replace the hydrophobic DDS bacterial and viral filter.
	Hose is kinked.	Check the hoses.
	DDS canister system: Float ball closes the suction area.	Check and if needed clean the float ball and the float ball compartment.

NOTICE

Two LEDs above the vacuum levels flash green.

No interference:

- The upper LED flashes green because this vacuum has been selected.
- The lower LED flashes green, as this vacuum level has almost been reached.

8.0 Accessories and consumables

Accessories	REF
Serres® external canister, 1 l	312.0465.0
Medi-Vac® external canister 1 l	312.0473.0
ATMOS external canister, 1 l	401.0100.0
AS secretion suction / portable / 1 l / ATMOS	HM57525803
DDS canister system 1 l, complete (with 10 x bacterial filter)	318.1000.0
DDS canister system 1 l, complete (with 1 x bacterial filter)	318.1040.0
Trolley for ATMOS Emergency Suction Device	318.1800.0
Car power cable for ATMOS Emergency Suction Device connection 12 V~	318.0036.0
Wall and device support for ATMOS Emergency Suction Devices	318.1250.0
Retrofit kit DDS canister system	318.1350.0
Retrofit kit Serres® canister system	318.1450.0
Retrofit kit Medi-Vac® canister system	318.1650.0
Consumables	REF
Suction hose, silicone, Ø 10 mm, L = 1.30 m, 1 pcs.	318.1012.0
Fingertip for suction hose, Ø 10 mm, 10 pcs.	318.1100.0
Hydrophobic DDS bacterial and viral filter, 10 pcs.	340.0054.0
Suction hose, PVC, CH 30, L = 1.30 m, 10 pcs.	006.0057.0
Suction hose, PVC, Ø 5.5 mm, L = 2.10 m, 50 pcs.	006.0059.0
Serres® suction bag 1 l without gelling agent, 36 pcs.	312.0466.0
Serres® suction bag 1 l with gelling agent, 32 pcs.	312.0467.0
Medi-Vac® suction bag 1 l, 50 pcs.	312.0474.0
ATMOS suction bag 1 l with gelling agent, 100 pcs.	401.0101.0
ATMOS suction bag 1 l, 100 pcs.	401.0102.0
Vacuum hose complete for disposable canister system	318.1211.0
Suction catheter Unomedical®, CH 12, 100 pcs.	000.0294.0
Suction catheter Unomedical®, CH 14, 100 pcs.	000.0295.0
Suction catheter Unomedical®, CH 16, 100 pcs.	000.0296.0
Hydrophobic bacterial and viral filter, Ø 11 mm	443.0738.0
DDS canister system	REF
DDS secretion canister 1 l	318.1013.0
DDS outer canister lid	318.1002.0
DDS inner canister lid	318.1004.0
Float ball	000.0839.0
Filter holder	318.1003.0
Sealing ring	055.0112.0
Device	REF
Battery for ATMOS E 341 Battery	319.0033.0

Battery compartment cover	318.0012.0
Hose rewind	319.0004.0
Device base	319.0003.0
Support for DDS canister system	318.1010.0
Support for Serres® canister system	318.1210.0
Support for Medi-Vac® canister system	318.1500.0
Release button	318.0013.0
Spring for release button	000.1029.0
Power supply and recharging unit	318.0035.0
2 pin power cord	008.0920.0

8.1 Wall and device support

Affix the power supply and recharging unit

Prerequisite: The Velcro fastener ❶ is attached to the wall and device support.

❶ Damaged cable due to incorrect mounting.

1. Please ensure that the power supply and recharging unit are positioned with the writing towards the wall or the standard rail. Otherwise the cable could be clamped.
2. Affix the parts ❷ and ❸ and fix the cable ❹ with the velcro fastener ❶.

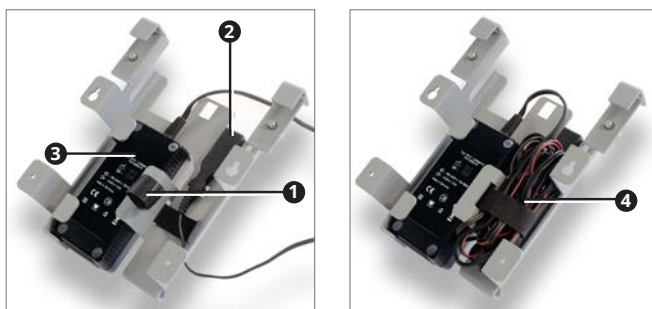

Wall mounting

- ☞ Only affix the power supply and recharging unit after you have marked the holes to be drilled.
 - ☞ Screws are not included in delivery.
1. Only use screws (max. 4 mm), which are suitable for the material of the wall.
 2. Position the wall and device support at an easily accessible place.
 3. Check whether the wall is smooth and vertical at the mounting position.
 4. Hold the wall and device support to the mounting location and align it with a spirit level.
 5. Mark the holes to be drilled on the wall.
 6. Drill the holes with a, the wall material and the chosen screws corresponding drill.
 7. Mount the power supply and recharging unit to the wall and device support. The power supply and recharging unit must not be connected to the mains supply.
 8. Screw the wall and device support to the wall with suitable screws.
 9. Connect the power supply and recharging unit to the mains supply.
 10. Check whether the charging accessory is correctly attached by installing the device.
 - » The battery will be charged.

Attach to / remove from a standard rail

Prerequisite: The power supply and recharging unit is mounted.

Mounting



Removal

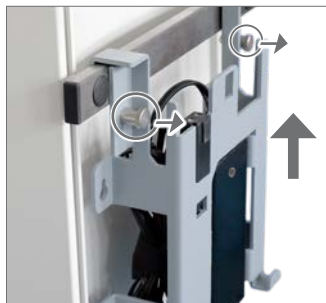

Attaching the device

1. Slide the device from above onto the wall and device support until it clicks into place.
- » If the charging accessory is attached, the battery is charged automatically.

Removing the device

1. Press the release button **1** and pull the device simultaneously vertically upwards.



8.2 Retrofit kit canister system

You may change the canister system. The retrofit kits comprise the canister system as well as the required support for the canister system. The retrofit kits for the disposable canister systems also comprise the vacuum hose.

Retrofitting

1. Remove the existing canister system, chapter "3.4 Connection and removal of canister system and hoses" on page 20.
2. Remove the existing support for the canister system.
3. Attach the new support for the canister system.
4. Insert the new canister system.

9.0 Disposal

Packaging

1. Recycle any device packaging you no longer need.

Secretion and blood

1. Please dispose of secretion, blood and contaminated parts in line with country-specific regulations.

In the Federal Republic of Germany the „Requirements on the implementation aid for disposal of waste from healthcare institutions“ are valid, a statement of the Federal / State Working Group on Waste.

Canister system

Single-use products may not be reprocessed and may not be reused! Please dispose of disposable products professionally.

The following notes are only applicable for reusable products.

1. Clean and disinfect the reusable products of the canister system.
2. Recycle the disinfected reusable products.

ATMOS E 341 Battery

Do not dispose of the device or the battery in domestic waste.

There is a lithium-ion battery included in the ATMOS E 341 Battery which must be disposed of in accordance with applicable guidelines.

1. Clean and disinfect the device.
2. In Germany: send the device back to ATMOS or your specialist dealer. They will dispose of the device professionally.
3. In other countries: Dispose of the device professionally and according to country-specific laws and regulations.



In Germany the device is excluded from the Electrical and Electronic Equipment Act (ElektroG) according to the National Register for waste electric equipment because it may be contaminated. Do not dispose of the device with electronic waste.

The housing is fully recyclable. Refer to the country-specific laws and regulations.



Expected service life

When the device is operated according to the instructions for use, it has an expected service life of 5 years. A regular thorough cleaning and disinfection of the device as well as operation in line with the instructions for use are assumed.

10.0 Technical data

Device

Input voltage	12 V DC nominal (at least 10 V, max. 15 V) at the charging interface or via the power supply and recharging unit
Current consumption	max. 3.7 A
Power consumption	max. 45 W
Pump	Vacuum pump (diaphragm pump), 1 head
Suction capacity at the device inlet (without canister system) at -0.8 bar, fully recharged battery and 21 °C / 1013 hPa (determined by buffer canister 1 l)	34 l/min ± 4 l/min
Suction capacity at the inlet of the reusable canister system at -0.8 bar, fully recharged battery and 21 °C / 1013 hPa	30 l/min ± 3 l/min
Maximum achievable vacuum	0.8 bar* ± 5 % resp. 80 % of the air pressure
Vacuum adjustment	Via predefined steps: -0.1 bar, -0.2 bar, -0.5 bar and -0.8 bar, electronically controlled
Vacuum display	By means of LEDs on the control panel
Display	By means of LEDs on the control panel: on/off, selected vacuum, actual vacuum, display of battery status, warning (red LED)
Mode of operation	Short-term operation 60 min ON, 120 min OFF
Noise level	< 60 dB(A) Mean sound pressure level in 1 m distance and at -0.8 bar
Environmental conditions: Transport/storage	
• Temperature range	-40...+70 °C
• Air humidity without condensation	5...95 %
• Air pressure	540...1100 hPa
Environmental conditions: Operation	
• Temperature range	-5...+50 °C
• Air humidity without condensation	5...95 %
• Air pressure	540...1100 hPa
Maximum operating altitude	5,000 m
Contamination level	1
Overvoltage category	II

Dimensions (H x W x D)	
<ul style="list-style-type: none"> with reusable canister system with disposable canister system Serres® with disposable canister system Medi-Vac® with universal bracket 	<p>37 x 27.7 x 14.6 cm</p> <p>37 x 27.7 x 14.6 cm</p> <p>37 x 27.7 x 13.6 cm</p> <p>37 x 27.7 x 13.6 mm</p>
Weight	
<ul style="list-style-type: none"> device with battery and without canister system and support with reusable canister system with disposable canister system Serres® with disposable canister system Medi-Vac® with universal bracket 	<p>3.65 kg</p> <p>1.00 kg (total: 4.65 kg)</p> <p>0.65 kg (total: 4.3 kg)</p> <p>0.295 kg (total: 3.95 kg)</p> <p>0.2 kg (total: 3.85 kg)</p>
Suspension	Compatible with ATMOS wall support
Periodic tests	Repeat test of the electrical safety every 24 months. Recommended: inspection according to manufacturer's specifications.
Protection class against electric shock (acc. to EN 60601-1)	II (during mains and battery operation)
Classification of applied parts	Type BF applied parts 
Classification according to EN ISO 10079-1	High vacuum / high flow
Degree of protection	IP34D
CE marking	 0124
Reference number (REF)	<p>319.1000.0 ATMOS E 341 Battery / DDS</p> <p>319.1100.0 ATMOS E 341 Battery / Serres®</p> <p>319.1200.0 ATMOS E 341 Battery / Medi-Vac®</p> <p>319.1300.0 ATMOS E 341 Battery with universal bracket</p>

*1 bar = 100 kPa

Battery

Type	Lithium-ion
Dimensions (W x H x D)	4.3 x 7.5 x 7.3 cm
Weight	0.41 kg
Nominal capacity	6.9 Ah
Nominal voltage	14.4 V nominal
Charging time	Battery status 80%: 4 h at 20 °C without operation; battery status 100%: approx. 6 h Automatic switch-over to trickle charging
Recharging interval during long-term storage	Every 6 months and recharge to 30%

Battery operating time during continuous operation with fully recharged battery / new battery (>20 l/min, setting -0.8 bar)	95 min at -5 °C 95 min at +21 °C 45 min at +50 °C
Life cycle	Approx. 500 recharging cycles
Display	Display of battery status during operation and recharging
Typical battery operating life*	-0.2 bar: 300 min -0.5 bar: 150 min -0.8 bar: 100 min
Environmental conditions: Storage (maximal)	
• Temperature range	-20 °C...+60 °C
• Air humidity without condensation	5...60 %
Environmental conditions: Storage (recommendation)	
• Temperature range	20 °C
• Air humidity without condensation	15...60 %
State of charge for storage	20 % - 30 %

*Measured at +21 °C, continuous operation, without battery recharging and at free air flow.

DDS canister system

Capacity	1000 ml
Connection reusable suction hose	Ø 10 mm I.D.
Reusable suction hose: Diameter Length	Ø 10 mm I.D. 1300 mm
Connection to the suction device	Direct connection (without intermediate hose)
Hydrophobic DDS bacterial and viral filter	Hydrophobic DDS bacterial and viral filter cartridge for use in the secretion canister lid, disposable
Bacterial filtration efficiency (BFE)	99.999778%*
Viral filtration efficiency (VFE)	99.73 %*
Overall filtration efficiency	>99.95%*
Filter class	H13 (High-Efficiency Particulate Air/ Arrestance)*

*External test report (test laboratory)

Disposable canister system

Capacity	1000 ml
Connection disposable suction hose	Ø 7 mm I.D.
Disposable suction hose: Diameter Length	Ø 6 mm I.D. 1300 mm
Connection to the suction device	By means of a vacuum hose (intermediate hose)
Bacterial filter	Integrated in the suction bag

Power supply and recharging unit

Dimensions (W x H x D)	13 x 3.6 x 6 cm
Weight	280 g
Environmental conditions: Transport/storage	
• Temperature range	-40...+70 °C
• Air humidity without condensation	10...95 %
• Air pressure	700...1100 hPa
Environmental conditions: Operation	
• Temperature range	0...+40 °C
• Air humidity without condensation	10...90 %
• Air pressure	700...1100 hPa
Electrical connection	100 V AC to 240 V AC 50 Hz to 60 Hz
Current consumption	Max. 1.1 A
Output nominal	13.8 V DC, 3.5 A
Protection class against electric shock (according to EN 60601-1)	II
Classification of applied parts	Type BF applied parts 
Degree of protection	IP40
Length of output line	1.8 m
Length of power supply cord	approx. 2 m

11.0 Notes on EMC

- Medical electrical equipment is subject to special precautions with regard to EMC and must be installed acc. to following EMC notes.

Guidance and manufacturer's declaration – ambient conditions

The product is suitable for use in the following environments:

- In fields of home health care in any buildings, outdoor areas, and means of transport.
- In professional healthcare facilities such as medical practices, hospitals/clinics, first-aid facilities and operating theatres/rooms.
It is not suitable for use in the vicinity of HF surgical devices and in settings outside of an HF-shielded room of a magnetic resonance imaging system.
- Special environments such as factory or military facilities and medical areas near HF surgical devices, short-wave therapy equipment or within an HF-shielded room of a magnetic resonance imaging system.

The customer or user must ensure that the device is used in a prescribed environment.

Guidance and manufacturer's declaration – key features

- Please note the technical data in these instructions. The essential features are fully usable even in the presence of electromagnetic disturbances.

Guidance and manufacturer's declaration – electrical components

The product has the following electrical components:

Type	REF	Max. cable length
Power supply and recharging unit for ATMOS C / E 341 Battery	318.0035.0	1.8 m
2-pin power cable	008.0920.0	1.5 m

Guidance and manufacturer's declaration – warnings

WARNING

The use of electrical components and accessories other than those specified or provided by the manufacturer may cause increased electromagnetic interference or reduced immunity to electromagnetic interference and result in faulty operation of the device.

WARNING

Portable RF communications equipment (e.g. radios, antenna cables) should not be used within 30 cm* of any parts or cables of the product as specified by the manufacturer. Failure to do so may lead to a reduction in the device's performance.

- *The distance may be reduced at higher immunity test levels.

WARNING

Placement on top of or next to another device should be avoided. This could result in faulty operation. If such placement cannot be avoided, the proper functioning of the device must be monitored regularly.

If possible, please switch off any nearby devices that are not in use.

12.0 Notes



MedizinTechnik

🏢 ATMOS MedizinTechnik GmbH & Co. KG

Ludwig-Kegel-Str. 16

79853 Lenzkirch / Germany

Phone: +49 7653 689-0

info@atmosmed.com

www.atmosmed.com