

Operating Instructions

ATMOS S 351 NATAL

English



GA1GB.210302.0

2025-04 Index 05



Table of contents

1	Introduction.....	4
1.1	Notes on operating instructions	4
1.2	Explanation of pictures and symbols	5
1.3	Intended use.....	8
1.4	Function.....	9
1.5	Intended users	10
1.6	Scope of delivery	10
1.7	Transport and storage	11
2	Notes for your safety.....	12
2.1	General safety instructions.....	12
2.2	Danger for users, patients and third parties	12
2.3	Avoiding damage to the device	15
3	Setting up and starting up	16
3.1	Device overview.....	16
3.1.1	Secretion canister	17
3.2	Preparing the device.....	18
3.3	Connecting to the mains power supply	18
3.4	Connecting the secretion canister system and hoses.....	19
4	Operation.....	20
4.1	Control panel.....	20
4.2	Switching on the device.....	20
4.3	Switching off the device.....	20
4.4	Explanation of the display.....	21
4.5	Vacuum extraction mode.....	21
4.6	User menu	22
4.6.1	Language	22
4.6.2	Vacuum unit	22
4.6.3	Vacuum extraction.....	22
4.6.4	Brightness.....	24
4.6.5	Date	24
4.6.6	Time.....	24
4.6.7	Vacuum steps	24
4.7	Vacuum extraction	25
4.7.1	Additional functions	25
4.7.2	Vacuum drop during vacuum build-up.....	26
4.7.3	Vacuum drop after final vacuum has been reached	26
4.7.4	Final vacuum is not reached.....	26
4.8	Suction.....	26
4.9	Electronic fill-level monitoring system.....	27
4.10	Changing the secretion canister.....	27
4.11	Warning messages.....	28
4.12	Trolley with standard rail ATMOS S 351 (REF 320.0070.0).....	29
4.13	Foot controller	29
4.14	Checking the bacterial and viral filter	29

5	Reprocessing.....	30
5.1	Safety instructions for reprocessing.....	30
5.1.1	General safety instructions.....	30
5.1.2	Danger for users, patients and third parties.....	30
5.1.3	Avoiding damage to the device.....	30
5.2	Preparing and completing reprocessing.....	31
5.3	Reprocessing surfaces.....	31
5.3.1	Overview.....	31
5.3.2	Selecting process chemicals.....	31
5.3.3	Wipe cleaning.....	32
5.3.4	Wipe disinfection.....	32
5.4	Reprocessing the accessories.....	33
5.4.1	Overview.....	33
5.4.2	Selecting process chemicals.....	33
5.4.3	Secretion canister system.....	34
5.4.4	Hoses.....	35
6	Maintenance and service.....	37
6.1	Periodic tests.....	37
6.2	Function check.....	37
6.2.1	Visual inspection.....	37
6.2.2	Function test.....	37
6.2.3	Monitoring.....	38
6.3	Sending in the device.....	39
7	Troubleshooting.....	40
8	Accessories.....	42
9	Disposal.....	44
9.1	Expected service life.....	44
10	Technical data.....	45
10.1	Hydrophobic DDS bacterial and viral filter.....	46
11	Notes on EMC.....	47

1 Introduction

1.1 Notes on operating instructions



These operating instructions contain important instructions on how to operate your product safely, correctly and effectively.

These operating instructions are designed for training and instructing new operating personnel in the use of the system, and they are also intended for use as a reference manual. This document may be reprinted, either in part or in whole, only with written permission from ATMOS.

These operating instructions must always be kept available near the product.



Care, periodic tests, regular cleaning and proper application are essential. They ensure the operational safety and usability of the product.

Maintenance, repairs, and periodic tests may be carried out only by persons who have the appropriate technical knowledge and are familiar with the product. The person must possess the test devices and original spare parts required to carry out these measures.



Read chapter '2 Notes for your safety' on page 12 before using the product for the first time. This will help you to avoid potentially dangerous situations.

The product bears the CE marking CE 0124 in accordance with EU Council Directive 93/42/EEC concerning medical devices and meets the basic requirements of Annex I to this directive.

The product complies with all the applicable requirements of Directive 2011/65/EU on the restriction of the use of certain hazardous substances in electrical and electronic equipment ('RoHS').

The Declarations of Conformity and our General Terms and Conditions can be viewed on our website at www.atmosmed.com.

The quality management system applied at ATMOS has been certified according to international standard EN ISO 13485.









These operating instructions are valid for the following devices:

ATMOS S 351 NATAL, 230 V	444.0401.0
ATMOS S 351 NATAL, 100 V	444.0401.1
ATMOS S 351 NATAL, 115 V	444.0401.2
ATMOS S 351 NATAL, 127 V	444.0401.3
ATMOS S 351 NATAL, 230 V	444.0491.0
ATMOS S 351 NATAL, 100 V	444.0491.1
ATMOS S 351 NATAL, 115 V	444.0491.2
ATMOS S 351 NATAL, 127 V	444.0491.3
ATMOS S 351 NATAL – basic set, 230 V	444.0490.0
ATMOS S 351 NATAL – basic set, 100 V	444.0490.1
ATMOS S 351 NATAL – basic set, 115 V	444.0490.2
ATMOS S 351 NATAL – basic set, 127 V	444.0490.3



ATMOS S 351 NATAL – basic set, 230 V (Medi-Vac®)	444.0492.0
ATMOS S 351 NATAL – basic set, 230 V (Serres®)	444.0493.0
ATMOS S 351 NATAL mobile, 230 V	444.0481.0
ATMOS S 351 NATAL mobile, 100 V	444.0481.1
ATMOS S 351 NATAL mobile, 115 V	444.0481.2
ATMOS S 351 NATAL mobile, 127 V	444.0481.3
ATMOS S 351 NATAL mobile with foot control, 230 V	444.0482.0
ATMOS S 351 NATAL mobile with foot control, 100 V	444.0482.1
ATMOS S 351 NATAL mobile with foot control, 115 V	444.0482.2
ATMOS S 351 NATAL mobile with foot control, 127 V	444.0482.3



















1.2 Explanation of pictures and symbols











In the operating instructions

 DANGER	Warning of a danger that will result in immediate fatal or serious injury. Observe the necessary measures.
 WARNING	Warning of a danger that can cause fatal or serious injury. Observe the necessary measures.
 CAUTION	Warning of a danger that can cause minor injury. Observe the necessary measures.
NOTICE	Notice of a danger that can damage the product or other objects. Observe the necessary measures.
	Warning of a danger that can cause fatal or serious injury.
	Notice of potential material damage.
	Useful information on the handling of the device.
1.	Action. Proceed step by step.
»	Result of an action.
	Move/plug in this direction.
	Engage, check correct fit.

On device and type plate

	Follow operating instructions (blue)
	Consult operating instructions
	Warning; pay special attention

	This product complies with the relevant requirements of EU Directives.
	This product complies with the relevant requirements of EU Directives.
	UL Listing Mark MEDICAL — GENERAL MEDICAL EQUIPMENT AS TO ELECTRICAL SHOCK, FIRE AND MECHANICAL HAZARDS ONLY IN ACCORDANCE WITH ANSI/AAMI ES60601-1 (2005) + AMD 1 (2012) CAN/CSA-C22.2 No. 60601-1 (2014) IEC 60601-1-6 (2013)
	Eurasian conformity
	Manufacturer
	Date of manufacture Country of manufacture
	Reference number
	Unique Device Identifier of a medical device
	Medical device
	Serial number
	Type B applied part
IPX0	No protection from water
	Professional disposal
	For single use only (symbol located on consumables)
	Product is sterile (unless packaging is damaged or opened)
	Autoclavable
	Connection for suction hose / patient (Serres® canister system)
	No natural rubber latex
	Potential equalisation
	Fuse

	Starting the vacuum extraction mode
	Stopping the vacuum extraction mode
—	Reduce vacuum
+	Increase vacuum
MAX	Maximum vacuum
SEMI	Vacuum extraction mode 'SEMI' activated
AUTO	Vacuum extraction mode 'AUTO' activated
S	Seconds
	Connected with trolley
	Foot controller
	This side up
	Fragile, handle with care
	Keep dry
	Keep away from sunlight
	Temperature limit
	Humidity limitation
	Atmospheric pressure limitation

UDI application identifier

(01)	UDI-DI: Identification of the manufacturer and the device
(10)	Batch code
(11)	Date of manufacture
(13)	Packing date

(17)	Expiry date
(21)	Serial number
(30)	Quantity in pieces

1.3 Intended use

Product name:	ATMOS S 351 NATAL
Main function:	<p>An electric suction pump controlled by a microprocessor generates negative pressure. Due to the controlled negative pressure, parts of the body, in particular the head of a baby, are fixed.</p> <p>The microprocessor allows the desired vacuum to be gently increased and decreased within the defined unit of time and enables a controlled shutdown of the pump.</p> <p>An additional secretion canister must be attached to allow for temporary collection of drained body fluids.</p>
Intended use / intended purpose:	Vacuum extraction, surgical suction (among others: suction curettage, suction biopsy), bronchial suction in newborns
Intended user / user profile:	Medical staff (among others: gynaecologists, midwives)
Intended patient group:	Generally, female patients of child-bearing age with and without restrictions; newborns.
Disease state to be diagnosed, treated or monitored:	Inapplicable
Application organ:	Natural orifices as well as openings resulting from surgical procedures (entire body)
Application time:	Short-term use on the patient (< 60 minutes)
Area of application:	The area of application is the clinical setting (among others: OT and delivery room). The device may only be used by staff who have been medically trained and instructed.
Criteria for patient selection:	Patients who benefit from vacuum extraction, a surgical procedure or bronchial suction
Indications:	<ul style="list-style-type: none"> • For vacuum extraction • In surgical procedures (e.g. suction curettage, suction biopsy) • For bronchial suction in newborns
Medical contraindications:	<p>Not suitable for:</p> <ul style="list-style-type: none"> • Continuous operation for drainage procedures in the low vacuum range (e.g. cardiothoracic or wound drainage). • Smoke evacuation • Liposuction • Emergency and rescue use

Other contraindications:

- No application outside of medical areas
- No suction of flammable, corrosive or explosive fluids/gases

Warning notes: The following complications can occur during vacuum extraction or suction:

- Cerebral haemorrhages
- Cephalohaematomas
- Skin abrasions on the child's head
- Haematomas
- Perineal, vaginal, cervical tears
- Bleeding
- Injuries to vessels and nerves
- Adhesion of the suction instrument

The product is: Active

Sterility / specific microbial condition: Not a sterile product

Single-use product / reprocessing: The device and parts of the accessories are reusable. For information on reprocessing, cleaning and disinfection, please see the operating instructions.

1.4 Function

The products are mains-operated medical suction devices designed for vacuum extraction, temporary surgical suction and bronchial suction in newborns. The product is employed during vacuum extraction to fix the baby's head with the aid of an extraction cup. In addition, suction material (among other things: secretion, blood) is temporarily collected in a collection canister and subsequently disposed of.

During operation, the pump generates vacuum in the secretion canister and hoses, by means of which the extraction cup can be fixed on the baby's head. Furthermore, secretion, blood and body fluids can be suctioned. The fluid is collected in the secretion canister. The buttons allow you to set the final vacuum and thus the suction capacity in steps. The set value can be read on the vacuum display. Once the final vacuum is reached, the pump turns off and only continues working if suction capacity falls below the final vacuum value.

Two vacuum extraction modes are available for vacuum extraction:

- **SEMI:** The device automatically generates a base vacuum of -20 kPa (-200 mbar; 150 mmHg). After reaching the base vacuum level, the user can check the correct positioning of the extraction cup. After confirming (by pressing button 1 (ON) for switching on automatic vacuum build-up), the device generates the desired final vacuum within the specified unit of time. Once the final vacuum has been reached, the device indicates this audibly and visually.
- **AUTO:** The device automatically generates the desired final vacuum within the specified unit of time. Once the final vacuum has been reached, the device indicates this audibly and visually.

After completing vacuum extraction or at any other time, the vacuum extraction mode can be stopped by pressing button 2 (OFF). The user can set the duration of the individual phases as well as the level of vacuum to be built up in the user menu.

1.5 Intended users

The device may be used only by trained and instructed medical professionals.

1.6 Scope of delivery

Legend:

Name	REF	Number
Basic device		1
Power cable 5 m	008.0629.0	2
Hydrophobic bacterial and viral filter	443.0738.0	3
Connecting hoses	999.0128.0 999.0127.0	4
Extraction hose, green, Ø 6 mm, L = 1.5 m	404.0146.0	5
Hose bracket for attaching to standard rail	444.0450.0	6
Secretion canister 1.5 l (PC)	444.0100.0	7
Double socket nipple with overflow electrode	444.0012.0	8
Secretion canister lid incl. standard rail holder	444.0015.0	9
Trolley with standard rail ATMOS S 351	320.0070.0	10
Foot control for ATMOS S 351	444.0478.0	11
Standard rail support Medi-Vac®	444.0451.0	12
Medi-Vac®-external canister 1 l	312.0473.0	13
Standard rail clamp Serres® complete	444.0484.0	14
Serres®-external canister	312.0465.0	15

Scope of delivery:

Basic device name	REF	Includes number
ATMOS S 351 NATAL, 230 V	444.0401.0	1, 2
ATMOS S 351 NATAL, 100 V	444.0401.1	1, 2
ATMOS S 351 NATAL, 115 V	444.0401.2	1, 2
ATMOS S 351 NATAL, 127 V	444.0401.3	1, 2
ATMOS S 351 NATAL, 230 V	444.0491.0	1, 2, 3, 4, 6
ATMOS S 351 NATAL, 100 V	444.0491.1	1, 2, 3, 4, 6
ATMOS S 351 NATAL, 115 V	444.0491.2	1, 2, 3, 4, 6
ATMOS S 351 NATAL, 127 V	444.0491.3	1, 2, 3, 4, 6
ATMOS S 351 NATAL – basic set, 230 V	444.0490.0	1–9
ATMOS S 351 NATAL – basic set, 100 V	444.0490.1	1–9
ATMOS S 351 NATAL – basic set, 115 V	444.0490.2	1–9
ATMOS S 351 NATAL – basic set, 127 V	444.0490.3	1–9
ATMOS S 351 NATAL – basic set, 230 V (Medi-Vac®)	444.0492.0	1, 2, 3, 4, 5, 6, 12, 13
ATMOS S 351 NATAL – basic set, 230 V (Serres®)	444.0493.0	1, 2, 3, 4, 5, 6, 14, 15
ATMOS S 351 NATAL mobile, 230 V	444.0481.0	1–10
ATMOS S 351 NATAL mobile, 100 V	444.0481.1	1–10
ATMOS S 351 NATAL mobile, 115 V	444.0481.2	1–10

ATMOS S 351 NATAL mobile, 127 V	444.0481.3	1-10
ATMOS S 351 NATAL mobile with foot control, 230 V	444.0482.0	1-11
ATMOS S 351 NATAL mobile with foot control, 100 V	444.0482.1	1-11
ATMOS S 351 NATAL mobile with foot control, 115 V	444.0482.2	1-11
ATMOS S 351 NATAL mobile with foot control, 127 V	444.0482.3	1-11

1.7 Transport and storage

Transport the product only in a shipping box that is padded and offers sufficient protection.

If damage occurs during transport:

1. Document and report damages in transit.
2. Send the device to ATMOS; see chapter '6.3 Sending in the device' on page 39.

Environmental conditions for transport and storage; see chapter '10 Technical data' on page 45.

2 Notes for your safety

Report all serious incidents that have occurred in connection with this product to the manufacturer and your national competent authority.

The safety of the ATMOS S 351 NATAL complies with the accepted standards of technology and the guidelines of the German Medical Devices Act.

2.1 General safety instructions

Familiarise yourself with the device in good time so that you are capable of operating it at any time.

Only a fully functional product meets the safety requirements of users, patients and third parties. Therefore, please observe the following instructions on your product:

Never operate the device if it shows any obvious safety defects.

2.2 Danger for users, patients and third parties

WARNING

Electric shock due to unsuitable mains power connection, incorrect handling of the product or damage to product components.

Burns, cardiac arrhythmias and even fatal injury are possible.

- Do not operate the device if it has been dropped. In this case, clean and disinfect the device and send it to ATMOS for repair.
- Prior to each use, check for damage to the device and the power cable. Do not operate the device if you notice any damage. In this case, clean and disinfect the device and send it to ATMOS for repair.
- You can disconnect the device from the mains power supply only by pulling out the power plug.
- Position the device in such a way that you can easily disconnect it from the mains power supply at any time.
- When disconnecting the device from the mains power supply, pull the power plug first and then the device plug.
- Disconnect the device from the mains power supply before cleaning or disinfecting it.
- Never touch the power plug or power cable with wet hands.
- Never immerse the device in water or other liquids.
- The device is not sterilisable.
- Use the power cable only in dry surroundings. The surroundings must be non-conductive.
- Ensure that no liquid enters the device. If liquid has entered the device, stop operating the device immediately; it must no longer be used. In this case, clean and disinfect the device and send it to ATMOS for repair.
- Use only original accessories and original spare parts from ATMOS. This applies to the power cable in particular.
- Follow the instructions regarding periodic tests in chapter '6 Maintenance and service' on page 37.
- Assembly, new settings, alterations, extensions, and repairs may be carried out only by authorised persons.
- Do not modify the device without the manufacturer's permission.

⚠ WARNING

Risk of infection due to patient secretion on the device!

Deadly diseases can be transmitted.

- Always wear disposable gloves if you could come into contact with secretion.
- Never use components marked with Ⓜ more than once. These components are intended for single use only.
- Sterile-packed parts may only be used if the packaging is undamaged.
- Never operate the device without a bacterial and viral filter.
- Before each use, check that the bacterial and viral filter is dry and clean to ensure that it operates correctly.
- A suction catheter, suction attachment or suction instrument must always be connected to the suction hose. The suction hose must never come into direct contact with the suction area.
- Clean and disinfect the device after every use.
- Clean and disinfect the device according to the operating instructions.
- The device must not be used following oversuction.

⚠ WARNING

Ensure that the device is always functional and ready for use.

Your patient can be severely injured.

- Ensure that the device is always ready for use.
- Place the device where it is easily accessible.
- Perform a function check after each use.
- ATMOS recommends always having another suction device ready at hand. That way you can also perform suctioning if a device should fail.
- Please observe the notes on the electromagnetic compatibility (EMC) of the device.

⚠ WARNING

Avoid improper use (vacuum extraction).

The baby can be severely injured.

- You as the treating user are responsible for the proper procedure and techniques! The appropriateness and the kind of application must be decided by a trained doctor on a case-by-case basis.
- The level of preselected vacuum and the selection of additional products must be made for all applications according to the corresponding specialist.
- Vacuum values that are too high can lead to tissue damage.
- Vacuum values that are too low can cause the extraction cup to tear off.
- Always use a secretion canister having a minimum capacity of 1 litre.
- Check the vacuum continuously during vacuum extraction.
- Use only transparent hoses or hoses intended for vacuum extraction.
- During vacuum extraction, the vacuum must be built up slowly in a controlled manner.
- During vacuum extraction, the system must not be ventilated suddenly while simultaneously pulling on the extraction cup.
- Using the foot controller during vacuum extraction disables the vacuum extraction automatic mode.
- Vacuum extraction is not possible at elevated altitudes, as it may not be possible to achieve the vacuum required.

⚠ WARNING

Avoid improper use (suction).

Your patient can be severely injured.

- Employ the device only according to its intended use.
- The product may be used only by medically trained persons who have been instructed in the handling of the medical suction system.
- Please select the vacuum according to the patient and the application.
- Observe the valid guidelines.
- Observe the notes on hygiene and cleaning.

⚠ WARNING

Explosion and fire hazard.

There is a risk of burns and injuries.

- Never suction any explosive, flammable or corrosive gases or liquids. Please observe the intended use in chapter '1.3 Intended use' on page 8.
- Never operate the product in potentially explosive areas or in areas that are oxygenated.
- Use only original accessories and original spare parts from ATMOS. This applies to the power cable in particular.

⚠ WARNING

Tripping hazard due to cables.

Injuries and fractures are possible.

- Lay the power cable properly.

⚠ WARNING

Contact may cause allergic reactions!

The materials used have been tested for their tolerability. In very rare cases, contact with accessible materials on the device and its accessories may cause allergic reactions. This applies in particular to contact injuries in conjunction with prolonged contact. If this occurs, seek medical attention immediately.

Only a fully functional product meets the safety requirements of users, patients and third parties. Therefore, please observe the following instructions on your product:

2.3 Avoiding damage to the device

NOTICE

Storage and operation in an unsuitable environment.

The electronics can become damaged.

- Please observe the environmental conditions for transport, storage and operation.
- Always place the device on firm, level ground. The device must always be in a vertical position when you use it. Otherwise, secretion can enter the device.

NOTICE

Damage to device due to heat build-up!

The device can become damaged.

- Do not cover the device during suction.
- Keep the device and the power cable away from other heat sources.
- Do not place the device directly next to other devices as this can cause excessive heating of the device.

NOTICE

Damage to the device due to improper use!

The device can become damaged.

- Ensure that no liquid enters the device. Once liquid has penetrated the device, it must no longer be operated. In this case, clean the device and send it to ATMOS for repair.
- Always place the device on firm, level ground. The device must always be in a vertical position when you use it.
- Use only power cables and extension cords that function properly.

3 Setting up and starting up

3.1 Device overview

Front view



- ❶ On/off switch
- ❷ Display
- ❸ Support for canister system
- ❹ Hydrophobic bacterial and viral filter
- ❺ Connection for suction hose
- ❻ Secretion canister lid
- ❼ Connection for extraction cup

Rear view



- ❶ Pump connection
- ❷ Connection for foot controller
- ❸ Service interface for data read-out
- ❹ Potential equalisation
- ❺ Mains supply

3.1.1 Secretion canister

Reusable canister system

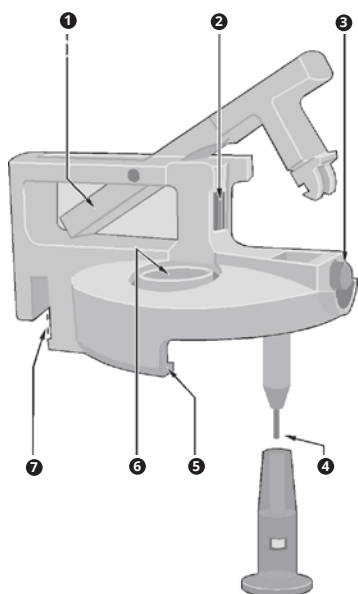

- ❶ Locking handle
- ❷ Knurled screw for locking the lid insert and for adjusting the clamping force
- ❸ Release button
- ❹ Fill-level sensor with anti-foaming device
- ❺ Lid rim
- ❻ Aperture for double hose connector
- ❼ Contacts for fill-level monitoring

Disposable canister system

ATMOS Disposable System (1 l)	
	<ul style="list-style-type: none"> ❶ Angle (connection for the disposable suction hose) ❷ ATMOS suction bag ❸ ATMOS external canister ❹ L-connector (connection for vacuum hose)
Serres® canister system	
	<ul style="list-style-type: none"> ❶ Angle (connection for the disposable suction hose) ❷ Serres® suction bag ❸ Serres® external canister ❹ Grey angle on the Serres® external canister (connection vacuum hose)

<p>Medi-Vac® canister system</p> 	<ul style="list-style-type: none"> ❶ Angle (connection for the disposable suction hose) ❷ Red hose ❸ Medi-Vac® suction bag ❹ Connection for vacuum hose ❺ Medi-Vac® external canister
<p>Standard rail holder ATMOS/Serres®</p> 	<p>Support for Medi-Vac®</p> 

3.2 Preparing the device



Prior to first operation, peruse the safety information in chapter '2 Notes for your safety' on page 12.

- ⓘ Damaged pump diaphragms due to cold temperatures during transport.
- 1. In case the device was transported at temperatures below -5 °C : let the device stand at room temperature for at least 6 hours before proceeding with the next steps.
- 2. Check the device, secretion canisters, power cable, accessories and hoses for possible damage.
- 3. If the device is damaged: document and report the damages in transit. Send the device to ATMOS (chapter '6.3 Sending in the device' on page 39).
- 4. If the device is not damaged: place the device on a safe, level surface.

3.3 Connecting to the mains power supply

- 1. Check whether the voltage and frequency data listed on the device correspond to the values of the mains power supply.
- 2. Connect the device to the mains.
- 3. Secure the power cable against accidental removal by using the safety clamp.

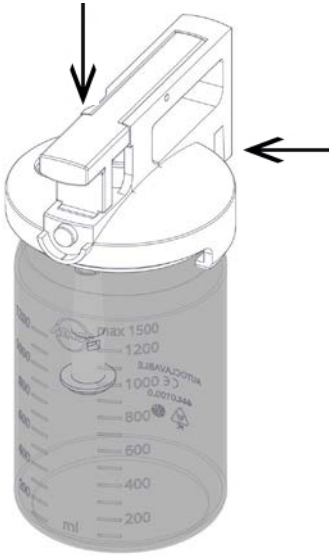
3.4 Connecting the secretion canister system and hoses

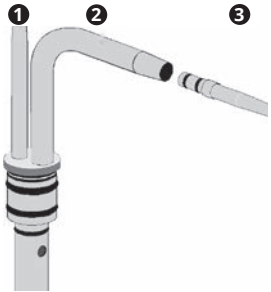
	<ol style="list-style-type: none"> 1. The anti-foaming device must be placed on the fill-level sensor for strongly foaming secretion. 2. Slide the secretion canister lid with the release button pointing forward onto the secretion canister. <ul style="list-style-type: none"> ☞ Make sure that the lid rim is under the bead of the secretion canister. This seals the secretion canister tightly and the desired vacuum can be built up in the secretion canister. 3. Press the locking handle downwards until it clicks into place. 4. Hang the secretion canister in the left or right support for the canister system. <p>ⓘ Using the support for the canister system for purposes other than what it was designed for can cause malfunctions.</p>
	<ol style="list-style-type: none"> 1. Push the double hose connector into the canister lid twisting gently. <ul style="list-style-type: none"> » The double hose connector locks into place.
	<ol style="list-style-type: none"> 1. Connect a short hose to the pipe connection on the device and to the bacterial and viral filter. 2. Connect a longer hose to the printed side of the bacterial and viral filter and to the vertical fitting of the double hose connector. <p>⚠ Never operate the device without a bacterial and viral filter.</p>
	<ol style="list-style-type: none"> 1. Connect the suction hose (Ø 10 mm) to the angled fitting (2) of the double hose connector. <ul style="list-style-type: none"> ☞ Use a hose reducer (3) for suction hose with a Ø of 6 mm. 2. Use the vacuum extraction suction hose to join the vertical fitting (1) of the double hose connector with the extraction cup.

4 Operation

Environmental conditions for operation; see chapter '10 Technical data' on page 45

4.1 Control panel

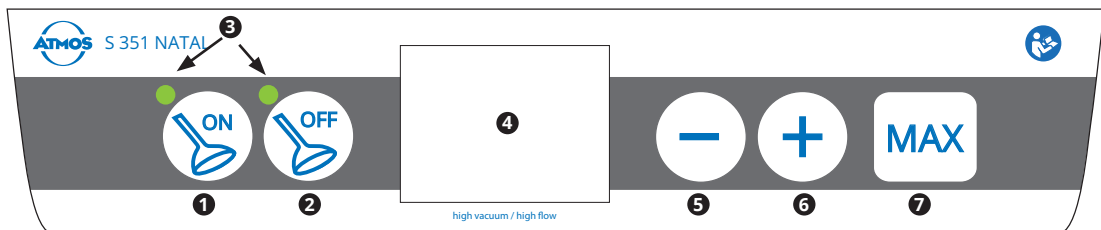

- ① Button for switching on the automatic vacuum build-up (ON)
- ② Button for switching off the automatic vacuum build-up (OFF)
- ③ LEDs for indicating the active function
- ④ Display
- ⑤ Button for reducing the vacuum
- ⑥ Button for increasing the vacuum
- ⑦ Button for selecting the maximum vacuum

4.2 Switching on the device

1. Press the on/off switch.
 - » The start screen appears.

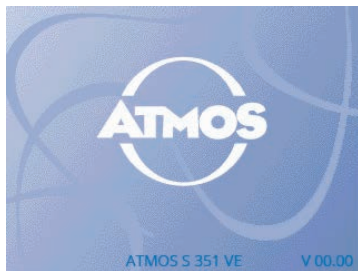



- » The pump starts automatically in the stored vacuum extraction mode (SEMI or AUTO).
- » By pressing button 2 (OFF), you stop vacuum extraction mode and are immediately redirected to suction mode.
- » The on/off switch remains lit as long as the device is switched on.

4.3 Switching off the device

1. Turn off the device by pressing the on/off switch. The display takes about 3–4 seconds to turn off.

4.4 Explanation of the display

The display shows the current settings of your ATMOS device.

	Connected with trolley
	Foot controller
SEMI	Semi-automatic vacuum extraction mode
AUTO	Automatic vacuum extraction mode

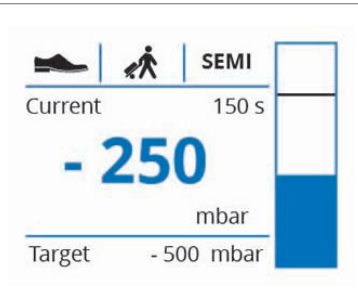
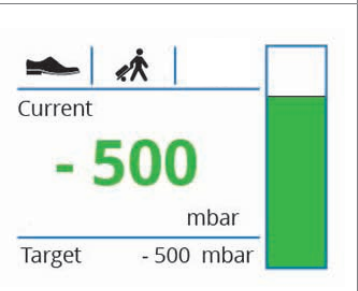
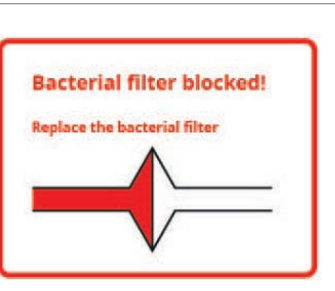
Variant 1:	Variant 2:	Variant 3:
		

In addition, the colours shown indicate the following:

- Blue: Vacuum is being generated or released
Final vacuum has not yet been reached
- Green: Final vacuum has been reached
- Red: Warning message or final vacuum cannot be generated
(e.g. due to leakage)

4.5 Vacuum extraction mode

Two vacuum extraction modes are available for vacuum extraction:

- **SEMI:** The device automatically generates a base vacuum of -20 kPa (-200 mbar; 150 mmHg). After reaching the base vacuum level, the user can check the correct positioning of the extraction cup. After confirming (by pressing button 1 (ON) for switching on automatic vacuum build-up), the device generates the desired final vacuum within the specified unit of time. Once the final vacuum has been reached, the device indicates this audibly and visually.
- **AUTO:** The device automatically generates the desired final vacuum within the specified unit of time. Once the final vacuum has been reached, the device indicates this audibly and visually.

After completing vacuum extraction or at any other time, the vacuum extraction mode can be stopped by pressing button 2 (OFF).

4.6 User menu

Display

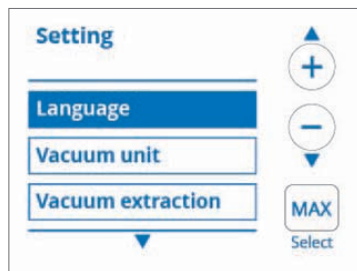

Operation

1. Press the on/off switch and immediately afterwards the ON BUTTON (1).
- » The user menu appears.
2. Press the - button (5) to scroll down in the user menu or + button (6) to scroll up.
3. Press the MAX button (7) to select the language, for example.

Options

- Language
- Vacuum unit
- Vacuum extraction
- Brightness
- Date
- Time
- Vacuum steps

4.6.1 Language

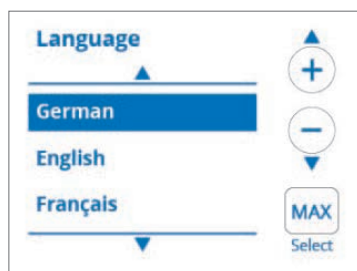

1. Press the + (6) or - (5) button to go to the desired language.
 2. Select the language by pressing the MAX button (7).
 - » The language is set. You are automatically redirected to the main menu.
- ☞ To return directly to the main menu, press the OFF button (2).

- German
- English
- Français
- Español
- Русский

4.6.2 Vacuum unit

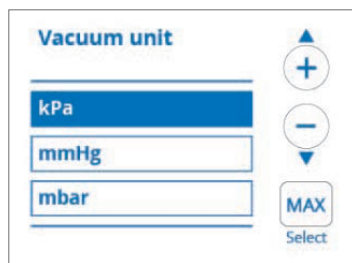

1. Press the + (6) or - (5) button to go to the desired vacuum unit.
 2. Select the vacuum unit by pressing the MAX button (7).
 - » The vacuum unit is set. You are automatically redirected to the main menu.
- ☞ To return directly to the main menu, press the OFF button (2).

- kPa
- mmHg
- mbar

4.6.3 Vacuum extraction

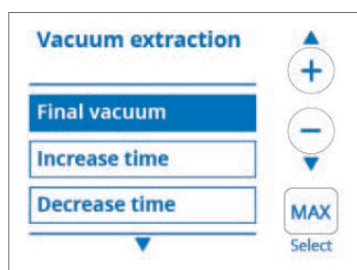

- Four parameters can be set in the vacuum extraction menu.
1. Press the + (6) or - (5) button to go to the desired parameter.
 2. Select the desired parameter by pressing the MAX button (7).
 - » The setting can now be made in the next window.
- ☞ To return directly to the main menu, press the OFF button (2).

- Final vacuum
- Increase time
- Decrease time
- Mode

Display

4.6.3.1 Final vacuum

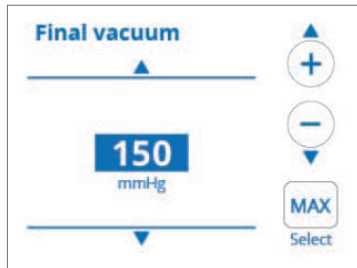

Operation

1. Press the + (6) or – (5) button to set the desired value.
 2. Confirm the value by pressing the MAX button (7).
- » The final vacuum is set. You are automatically redirected to the vacuum extraction menu.
- ☞ To return directly to the vacuum extraction menu, press the OFF button (2).

Options

- min. –70 kPa
- max. –90 kPa
- min. –700 mbar
- max. –900 mbar
- min. –525 mmHg
- max. –675 mmHg

4.6.3.2 Increase time

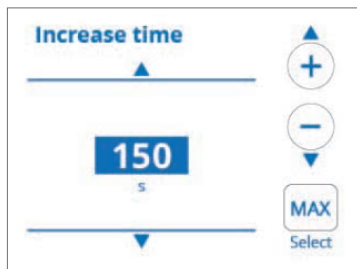

1. Press the + (6) or – (5) button to set the desired value.
 2. Confirm the value by pressing the MAX button (7).
- » The increase time is set. You are automatically redirected to the vacuum extraction menu.
- ☞ To return directly to the vacuum extraction menu, press the OFF button (2).

- min. 15 sec
- max. 300 sec

4.6.3.3 Decrease time

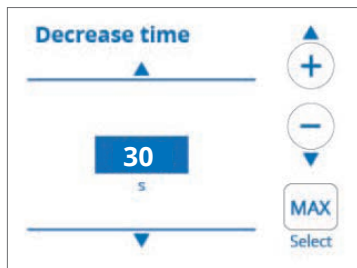

1. Press the + (6) or – (5) button to set the desired value.
 2. Confirm the value by pressing the MAX button (7).
- » The decrease time is set. You are automatically redirected to the vacuum extraction menu.
- ☞ To return directly to the vacuum extraction menu, press the OFF button (2).

- min. 15 sec
- max. 60 sec

4.6.3.4 Mode

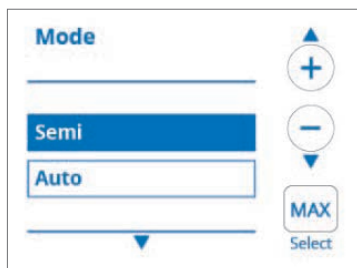

1. Press the + (6) or – (5) button to set the desired mode.
 2. Confirm the value by pressing the MAX button (7).
- » The mode is set. You are automatically redirected to the vacuum extraction menu.
- ☞ To return directly to the vacuum extraction menu, press the OFF button (2).

- SEMI
- AUTO

Display

4.6.4 Brightness

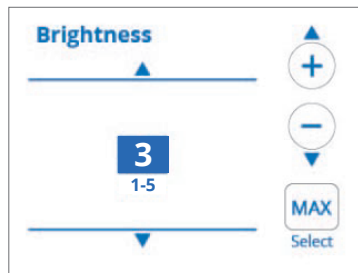

Operation

1. Press the + (6) or – (5) button to go to the desired level of brightness.
 2. Select the level of brightness by pressing the MAX button (7).
- » The level of brightness is set. You are automatically redirected to the main menu.
- ☞ To return directly to the main menu, press the OFF button (2).

Options

- Levels 1–5

4.6.5 Date



1. Press the + (6) or – (5) button to set the day, month and year.
 2. Confirm the day, month and year by pressing the MAX button (7).
- » The date is set. You are automatically redirected to the main menu.
- ☞ To return directly to the main menu, press the OFF button (2).

- Day
- Month
- Year

4.6.6 Time

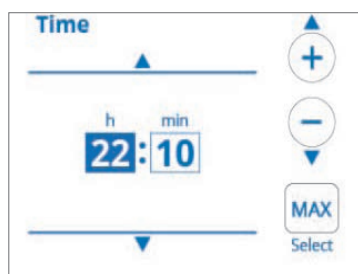

1. Press the + (6) or – (5) button to set the hour and minutes.
 2. Confirm the hour and minutes by pressing the MAX button (7).
- » The time is set. You are automatically redirected to the main menu.
- ☞ To return directly to the main menu, press the OFF button (2).

- Hour
- Minute

4.6.7 Vacuum steps

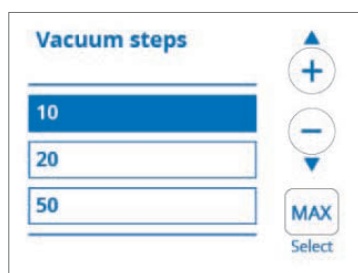

1. Press the + (6) or – (5) button to go to the desired vacuum steps.
 2. Select the vacuum steps by pressing the MAX button (7).
- » The vacuum steps are set. You are automatically redirected to the main menu.
- ☞ To return directly to the main menu, press the OFF button (2).

For vacuum unit in mbar:

- 10
- 20
- 50

For vacuum unit in kPa:

- 1
- 2
- 5

For vacuum unit in mmHg:

- 7
- 15
- 37

4.7 Vacuum extraction

- For vacuum extraction, we recommend that you use a small secretion canister (1.5 l) so that the required vacuum can be generated with the least possible delay.
 - During automatic vacuum build-up, the ATMOS S 351 NATAL generates vacuum evenly and the final vacuum is reached in the preset time.
 - The device offers you the possibility of choosing between fully automatic (AUTO) and semi-automatic (SEMI) vacuum build-up.
1. Press the on/off switch.
 - » The start screen appears.
 - » The pump starts automatically in the stored vacuum extraction mode (SEMI or AUTO).
 - » By pressing button 2 (OFF), you stop the vacuum extraction mode and are immediately redirected to suction mode.
 - » The on/off switch remains lit as long as the device is switched on.
 2. Apply the extraction cup.

AUTO:

- » After the base vacuum of -20 kPa has been reached, automatic vacuum build-up is started and is indicated by an advisory tone. The remaining time (in seconds) to final vacuum is shown on the middle right of the display.
- » An advisory tone signals that the final vacuum has been reached, and the LED lights up green.
- » The final vacuum is held.
- ☞ You can now begin with vacuum extraction.

SEMI:

- » An advisory tone sounds when the base vacuum of -20 kPa has been reached. Check the positioning of the extraction cup.
 - » For SEMI mode, the start of automatic vacuum build-up must be confirmed by pressing button 1 (ON). The remaining time (in seconds) to final vacuum is shown on the middle right of the display.
 - » An advisory tone signals that the final vacuum has been reached, and the LED lights up green.
 - » The final vacuum is held.
 - ☞ You can now begin with vacuum extraction.
3. After completing vacuum extraction or at any other time within vacuum extraction mode, you can ventilate the extraction cup in a controlled manner over a predefined period by pressing button 2 (OFF). After the extraction cup has been ventilated completely, the device is in suction mode.
 4. It is possible to repeat automatic vacuum build-up for vacuum extraction by pressing button 1 (ON).

4.7.1 Additional functions

1. Adjusting the final vacuum:
 - Once the final vacuum has been reached, the vacuum can be reduced by pressing the $-$ button (5).
 - Once the final vacuum has been reached, the vacuum can be increased by pressing the $+$ button (6).

2. Adjusting the vacuum increase time:
 - The vacuum increase can be delayed by pressing the – button (5) during vacuum build-up. The counter reading for the time unit increases accordingly.
 - The vacuum increase can be accelerated by pressing the + button (6) during vacuum build-up. The counter reading for the time unit decreases accordingly.
3. Adjusting the vacuum decrease time:
 - The vacuum decrease can be accelerated by pressing the – button (5) during vacuum build-up. The counter reading for the time unit decreases accordingly.
 - The vacuum decrease can be delayed by pressing the + button (6) during vacuum release. The counter reading for the time unit increases accordingly.

4.7.2 Vacuum drop during vacuum build-up

- If the vacuum drops during automatic vacuum build-up, the device issues a warning signal: fast flashing of a red LED and a beeping sound synchronised with the blinking LED. The time display remains on the value reached until vacuum build-up can be continued.
 - The pump output is increased, if possible, to counteract the leak.
 - The warning signal stops as soon as vacuum build-up can be continued or after the user cancels the action.
- ☞ The ATMOS S 351 NATAL cannot predict that the extraction cup will tear off. There is no warning for this.

4.7.3 Vacuum drop after final vacuum has been reached

- If the vacuum falls below –70 kPa after the final vacuum has been reached, the device issues a warning signal: fast flashing of a red LED and a beeping sound synchronised with the LED. The font colour on the display changes from green to red.
 - The warning signal stops as soon as vacuum build-up can be continued or after the user cancels the action.
- ☞ The ATMOS S 351 NATAL cannot predict that the extraction cup will tear off. There is no warning for this.

4.7.4 Final vacuum is not reached

- If the time for vacuum build-up has elapsed and the final vacuum has not been achieved, the device will wait for about another 35 s and then issue a warning signal: fast flashing of a red LED and a beeping sound synchronised with the blinking LED.
- The warning signal indicates a leak in the system which prevents the final vacuum from being achieved.
- The warning signal stops as soon as the final vacuum is reached again or after the user cancels the action.

4.8 Suction

WARNING

Vacuum is too high.

Patient can be seriously injured.

- Observe the valid guidelines.
- Please select the vacuum according to the patient and the application.

1. Press the on/off switch.
 - » The start screen appears.
 - » The pump starts automatically in the stored vacuum extraction mode (SEMI or AUTO).
- ☞ By pressing button 2 (OFF), you stop the vacuum extraction mode and are immediately redirected to suction mode.
- ☞ Keeping the – (5) or + (6) button pressed changes the vacuum value faster.
 - » The on/off switch remains lit as long as the device is switched on.

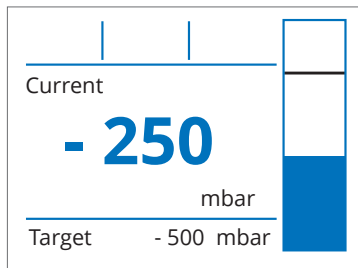

1. Press the + (6), button, – (5) button or MAX (7) button to set the target vacuum.
 - » The target vacuum at the bottom of the display and the black line in the right bar change.
 - » The current vacuum in the middle of the display and the blue bar change.
- ☞ Keeping the – (5) or + (6) button pressed changes the vacuum value faster.

When the final vacuum has been reached, the indicator for the current vacuum in the display changes from blue to green.

4.9 Electronic fill-level monitoring system

The ATMOS S 351 NATAL has an electronic fill-level monitoring system that switches off the pump when the maximum fill level is reached. At the same time, the device beeps and then *Secretion canister full* appears in the display. The maximum fill level is reached when the liquid comes into contact with the sensor in the secretion canister lid. If a large amount of foam is generated, you should fit the enclosed anti-foaming device over the sensor so that the pump does not switch off prematurely. As soon as the sensor is no longer in contact with the liquid (e.g. on replacing the double hose connector), the pump switches on again.

4.10 Changing the secretion canister

Change or empty the secretion canister when it is 2/3 full.





WARNING

Risk of infection.

Death or serious injuries from infection.

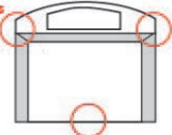
- ☞ Always wear disposable gloves when changing the secretion canister.
 1. Stop the suction process by switching off the pump.
 2. Remove the double hose connector from the full secretion canister.
 3. If a second secretion canister is attached, insert the double hose connector into it.
 4. Lift the full secretion canister with its lid upwards. Press the release button and open the locking handle.
 5. Empty the secretion canister or replace it with a new one.
- ☞ Dispose of the suction material properly.
 6. Attach the canister lid to the empty secretion canister and then to the device.
 7. Attach the double hose connector to the secretion canister.

4.11 Warning messages

Display	Cause	Troubleshooting
<p>Bacterial filter blocked!</p> <p>Replace the bacterial filter</p> 	<p>The hydrophobic bacterial and viral filter is blocked.</p> <p>☞ This warning message also appears if there is a kink in the hose or if drainage accessories are connected.</p>	<p>Replace the hydrophobic bacterial and viral filter.</p>
<p>Short circuit!</p> <p>Check contacts on the device</p> 	<p>Short circuit between the contact terminals.</p>	<p>Check the contacts on the device.</p>
<p>Secretion canister full!</p> <p>Replace the secretion canister</p> 	<p>The secretion canister is full.</p>	<p>Change the secretion canister.</p> <p>In the event of strong foaming: Fit the anti-foaming device over the sensor.</p> <p>Please observe: The warning message 'Secretion canister full' is deactivated when disposable canister systems are in use.</p>
<p>Device temperature too high!</p> <p>Provide sufficient ventilation</p> 	<p>The device temperature is too high.</p>	<p>Please provide sufficient cooling.</p>
<p>Service required!</p> <p>Device cannot be operated. Please contact service</p> 	<p>Service is required.</p>	<p>Contact ATMOS Service.</p>

4.12 Trolley with standard rail ATMOS S 351 (REF 320.0070.0)



1. Mount the device on the trolley tray using a screw.

4.13 Foot controller

During extraction mode, it is possible to transfer the control of the vacuum to the connected foot controller. In this case, the ATMOS S 351 NATAL automatically goes into suction mode.

The vacuum can be set by connecting the foot controller:

1. Plug the foot controller into the connection.
 2. Connect the suction catheter, suction attachment or suction instrument to the suction hose.
 3. Switch on the ATMOS S 351 NATAL. Make sure that the pilot lamp in the on/off switch lights up.
 4. Select the final vacuum required using one of the buttons (5), (6) and (7). Keeping the – (5) and + (6) buttons pressed changes the value faster.
 5. You can now vary the vacuum between 0 and the preset final vacuum value by using the foot controller.
- ☞ Using the foot controller during vacuum extraction disables the vacuum extraction automatic mode.

4.14 Checking the bacterial and viral filter

NOTICE

The bacterial and viral filter is a disposable product and cannot be autoclaved or disinfected.

1. Switch on the device.
2. Press the MAX button.
3. As soon as the current vacuum on the display shows a vacuum greater than –300 mbar (–30 kPa / –225 mmHg) with the suction hose open, you have to change the bacterial filter.
4. To do this, remove the hose connections on the bacterial and viral filter and insert a new one. Pay attention to the correct flow direction.
5. Dispose of the used bacterial and viral filter immediately so that it is not used again accidentally.
6. Recommendation: Always have some replacement bacterial and viral filters ready at hand.

5 Reprocessing

5.1 Safety instructions for reprocessing

5.1.1 General safety instructions

We recommend that you always document all maintenance work and part replacements in writing.

It is the responsibility of the user to ensure that the required results of cleaning and disinfection are achieved. Generally, validation and routine monitoring of the procedure will be necessary.

Reprocessing may be carried out only by persons who have the necessary expertise. The person must have the necessary equipment to carry out these measures.

5.1.2 Danger for users, patients and third parties

⚠ WARNING

Risk of infection due to unsuitable medical aids.

Deadly diseases can be transmitted.

- Always wear your own personal protective equipment. The protective equipment consists of protective gloves, protective clothing, goggles and mouth and nose protection for all steps in which the product components are still contaminated.
- Use only aids that can be easily reprocessed or ones that are disposable products.

⚠ WARNING

Risk of infection due to unsuitable reprocessing.

Deadly diseases can be transmitted.

- Make sure that all areas of the accessories can be reached easily.
- Use only suitable load carriers for mechanical reprocessing. This especially applies to accessories with hollow spaces and lumens that are hard to reach.
- Make sure that air bubbles do not form in the hollow spaces and lumens of accessories when placing them in processing solutions.

5.1.3 Avoiding damage to the device

Damage to the device due to cleaning with fixatives.

Stains and soiling cannot be removed permanently.

- Do not use aldehydes before and during cleaning.
- Do not expose the product to temperatures above 40 °C before and during cleaning.

Unsuitable aids.

The product can become damaged.

- Use only lint-free, soft cloths.
- Always use demineralised water for the final rinse.
- Follow the corresponding operating instructions of all aids and devices used.

Unsuitable cleaning agents and disinfectants.

The product can become damaged.

- Do not use any process chemicals containing the following ingredients on **plastic parts**:
 - Chloramides or phenol derivatives
- Do not use abrasives.

5.2 Preparing and completing reprocessing

Prior to reprocessing

1. Disassemble the product into the following items for reprocessing:
 - Secretion canister system (secretion canister, secretion canister lid, double hose connector, bacterial and viral filter)
 - Hoses (suction hose, vacuum hose, connecting hose)

After reprocessing

1. Perform a function check.

5.3 Reprocessing surfaces

5.3.1 Overview

Surface	After each use	After each patient	Daily	Weekly	Every 14 days	Monthly	Pre-cleaning	Wipe cleaning	Wipe disinfection	Spray disinfection	Remarks
Coated surfaces	X							X	X		According to the agent manufacturer's instructions
Other surfaces	X							X	X		According to the agent manufacturer's instructions

5.3.2 Selecting process chemicals

Follow the manufacturer's instructions for the process chemical.

Cleaning agent (manufacturer)	Active ingredients in 100 g	Type	Coated surface	Other surface
Disinfection				
Green & Clean SK (Metasys)	<1 g dialkyldimethylammonium chloride, <1 g alkylidimethylethylbenzylammonium chloride, <1 g alkylidimethylbenzylammonium chloride	Liquid	X	
Dismozon® plus (Bode Chemie)	95.8 g magnesium monoperoxyphthalate hexahydrate	Granulate	X	X

Cleaning agent (manufacturer)	Active ingredients in 100 g	Type	Coated surface	Other surface
Kohrsolin® FF (Bode Chemie)	5 g glutaral, 3 g benzyl-C12-C18-alkyldimethylammonium chloride, 3 g didecyldimethylammonium chloride	Liquid concentrate	X	X
Kohrsolin® extra (Bode Chemie)	14.1 g (ethylenedioxy)dimethanol, 5 g glutaral, 8 g didecyldimethylammonium chloride	Liquid concentrate	X	X
perform® (Schülke & Mayr)	45 g pentapotassium-bis(peroxymonosulphate) bis(sulphate), anionic surfactants, non-ionic surfactants, phosphonates	Powder	X	X
terralin® protect (Schülke & Mayr)	22 g alkyl(C12-16)dimethylbenzylammonium chloride (ADBAC/BKC (C12-16)), 17 g 2-phenoxyethanol, 0.9 g amines, N-C12-14- (even-numbered)-alkyltrimethylenedi-, reaction products with chloroacetic acid	Liquid concentrate		X
FD 312 (Dürr Dental)	6.5 g alkyl-benzyl-dimethyl-ammonium chloride	Liquid concentrate		X
Bacillo® 30 Foam (Bode Chemie)	14 g ethanol, 10 g propan-2-ol, 6 g propan-1-ol, 0.5 g n-alkyl-aminopropyl-glycine	Foam	X	X
SaniCloth® Active (Ecolab)	0.45 g didecyldimethylammonium chloride	Wipes		X
Incidin® Active (Ecolab)	Peracetic acid	Powder		X
mikrozid® sensitiv wipen (Schülke & Mayr)	0.26 g alkyl(C12-16)dimethylbenzylammonium chloride, 0.26 g didecyldimethylammonium chloride, 0.26 g alkyl(C12-14)ethylbenzylammonium chloride	Wipes		X
Mikrobac® forte (Bode Chemie)	0.4 g benzyl-C12-18-alkyldimethylammonium chloride, 0.4 g didecyldimethylammonium chloride	Wipes		X
Hexaquart® forte (BBraun)	Quaternary ammonium compounds, 20.0 g benzyl-C12-16-alkyldimethyl, chlorides, 7.9 g didecyldimethylammonium chloride	Liquid concentrate		X
Meliseptol® Wipes sensitive (BBraun)	17 g propan-1-ol, 0.23 g didecyldimethylammonium chloride	Wipes		X
Meliseptol® Foam pure (BBraun)	17 g propan-1-ol, 0.23 g didecyldimethylammonium chloride	Foam		X
Incidin® Plus (Ecolab)	26 g Glucoprotamin	Liquid concentrate		X

5.3.3 Wipe cleaning

1. Disconnect the device from the mains power supply.
2. Clean the surface evenly with a suitable cloth and suitable cleaning agent; see chapter '5.3.1 Overview' on page 31. Pay particular attention to hard-to-reach areas.
 - » No more residue is visible.

5.3.4 Wipe disinfection

1. Disinfect the surface evenly with a suitable cloth and suitable disinfectant. Pay particular attention to hard-to-reach areas.
2. Wait for the contact time to elapse.

5.4 Reprocessing the accessories

5.4.1 Overview

Accessory	Disposable product	Max. reprocessing cycles	After each use	After each patient	Daily	Weekly	Every 14 days	Monthly	Pre-treatment	Pre-cleaning	Manual cleaning and disinfection	Mechanical cleaning and disinfection	Sterilisation
Secretion canister system													
Secretion canister		50	X						X	X		X	X
Secretion canister lid		50	X						X	X		X	X
Double hose connector		50	X						X	X		X	X
Bacterial and viral filter ¹	X												
Hoses													
Suction hose		60	X						X	X		X	X
Vacuum hose		60	X						X	X		X	X
Connecting hose		60	X						X	X		X	X

¹ Immediate filter change in the event of discolouration, contamination, oversuction. The bacterial filter is no longer in optimum condition if the vacuum displayed is above -0.3 bar when the vacuum regulator is in the 'MAX' position and the suction hose is open.

5.4.2 Selecting process chemicals

Follow the manufacturer's instructions for the process chemical.

Cleaning agent (manufacturer)	Active ingredients in 100 g	Type	Secretion canister system	Hoses
Disinfectants - Manual reprocessing				
gigasept® FF new (Schülke & Mayr)	<5% phosphonates, <5% anionic surfactants, <5% non-ionic surfactants, perfumes, methylisothiazolinones	Liquid concentrate	X	
Cleaning agents - Mechanical reprocessing				
neodisher® MediClean forte (Dr. Weigert)	<5% non-ionic and anionic surfactants, enzymes	Liquid concentrate		X

5.4.3 Secretion canister system

Characteristics

The accessories have the following hard-to-reach areas:

- Double hose connector (lumens)
- Secretion canister lid complete (hollow spaces)

Take particular care when reprocessing hard-to-reach areas.

<p>Pre-treating at the site of use</p> <p>Flushing: 60 s Rinsing: 60 s</p>	<ol style="list-style-type: none"> 1. Empty the secretion canister. 2. Clean the accessories under cold, running water. 3. Thoroughly rinse out the hollow spaces and lumens of the accessories with running water. <ul style="list-style-type: none"> » No more residue is visible.
<p>Collecting and transporting</p>	<ol style="list-style-type: none"> 1. Label any damaged accessories. 2. Place the accessories in a canister. 3. Transport the canister to the reprocessing site.
<p>Disassembly</p>	<p>See chapter '3 Setting up and starting up' on page 16.</p> <ol style="list-style-type: none"> 1. Discard disposable products.
<p>Pre-cleaning</p> <p>Flushing: 1x / 30 s Rinsing: 60 s</p> <p>Brush: Round brush • Diameter: 7 / 11 / 15 mm • Material: Nylon • Characteristics: With angled head</p>	<p>☞ Pre-cleaning is necessary only for mechanical cleaning and disinfection.</p> <ol style="list-style-type: none"> 1. Make the following hollow spaces accessible: <ul style="list-style-type: none"> • Double hose connector • Entire secretion canister lid 2. Make the following lumens accessible: <ul style="list-style-type: none"> • Double hose connector 3. Clean the accessories evenly with a suitable brush under running water. 4. Thoroughly rinse out the hollow spaces and lumens of the accessories with running water.
<p>Mechanical cleaning and disinfection</p> <p>Pre-rinse: 1 min Clean: 5 min 50 °C / 122 °F Neutralise: 2 min Intermediate rinse: 1 min Disinfect: 5 min 60 °C / 140 °F Dry: 12 min 110 °C / 230 °F</p>	<ol style="list-style-type: none"> 1. Empty the secretion canister. 2. Clean and disinfect using a suitable programme: <ul style="list-style-type: none"> • Pre-rinse with cold water • Cleaning with cleaning agent • Neutralisation with neutralising agent • Intermediate rinse with softened, cold water • Disinfection with suitable disinfectant and demineralised water • Drying <p>Washer-disinfectors: • In accordance with EN ISO 15883-1</p> <p>Programme: • Miele Vario TD</p> <p>Adapter: • Adapter Miele E329</p>

Checking and maintaining	<ol style="list-style-type: none"> 1. Check whether reprocessing was successful with a suitable light magnifier. <ul style="list-style-type: none"> • Free of particles and organic material 2. Dispose of damaged accessories or have them repaired.
Assembly	Not necessary.
Function check	Not necessary.
Packaging	<ol style="list-style-type: none"> 1. Label the accessories. 2. Pack the accessories using a packaging system according to DIN EN ISO 11607.
Sterilisation Pre-fractionated 3x vacuum: Temperature: 134 °C / 273 °F Time: 5 min Dry: 10 min	<ol style="list-style-type: none"> 1. Sterilise the accessories using a suitable procedure: <ul style="list-style-type: none"> • Steam sterilisation / autoclaving <p>☞ Ideally, always use the same procedure.</p> <p>Steriliser: • In accordance with EN 285</p>
Storage	<ol style="list-style-type: none"> 1. Observe the environmental conditions; see chapter '10 Technical data' on page 45.

5.4.4 Hoses

Pre-treating at the site of use Flushing: 5x / 30 s	<ol style="list-style-type: none"> 1. Clean the accessories under cold, running water. 2. Thoroughly rinse out the hollow spaces and lumens of the accessories with running water. <ul style="list-style-type: none"> » No more residue is visible.
Collecting and transporting	<ol style="list-style-type: none"> 1. Label any damaged accessories. 2. Place the accessories in a canister. 3. Close the canister. 4. Transport the canister to the reprocessing site.
Pre-cleaning Flushing: 5x / 30 s	<p>☞ Pre-cleaning is necessary only for mechanical cleaning and disinfection.</p> <ol style="list-style-type: none"> 1. Clean the accessories evenly under running water. 2. Thoroughly rinse out the hollow spaces and lumens of the accessories with running water.
Disassembly	Not necessary.

<p>Mechanical cleaning and disinfection</p> <p>Pre-rinse: 1 min Clean: 5 min 55 °C / 131 °F Neutralise: 2 min Disinfect: 5 min 93 °C / 199 °F Dry: 12 min 110 °C / 230 °F</p>	<ol style="list-style-type: none"> 1. Empty the secretion canister. 2. Clean and disinfect using a suitable programme: <ul style="list-style-type: none"> • Pre-rinse with cold water • Cleaning with cleaning agent • Neutralise with cold water • Intermediate rinse with softened, cold water • Disinfection with suitable disinfectant and demineralised water • Drying <p>Washer-disinfector: • In accordance with EN ISO 15883-1</p> <p>Programme: • Miele Vario TD</p> <p>Adapter: • Miele E336/E446</p>
<p>Checking and maintaining</p>	<ol style="list-style-type: none"> 1. Check whether reprocessing was successful with a suitable light magnifier. 2. If reprocessing was unsuccessful, reprocess the accessories again. 3. Dispose of damaged accessories or have them repaired.
<p>Assembly</p>	<p>Not necessary.</p>
<p>Function check</p>	<p>Not necessary.</p>
<p>Packaging</p>	<ol style="list-style-type: none"> 1. Label the accessories. 2. Pack the accessories using a packaging system according to DIN EN ISO 11607.
<p>Sterilisation</p> <p>Pre-fractionated 3x vacuum: Temperature: 134 °C / 273 °F Time: 5 min Dry: 10 min</p>	<ol style="list-style-type: none"> 1. Sterilise the accessories using a suitable procedure: <ul style="list-style-type: none"> • Steam sterilisation / autoclaving <p>☞ Ideally, always use the same procedure.</p> <p>Steriliser: • In accordance with EN 285</p>
<p>Storage</p>	<ol style="list-style-type: none"> 1. Observe the environmental conditions; see chapter '10 Technical data' on page 45.

6 Maintenance and service

Maintenance, repairs, and periodic tests may be carried out only by persons who have the appropriate technical knowledge and are familiar with the product. The person must possess the test devices and original spare parts required to carry out these measures.

ATMOS recommends: work should be carried out by an authorised ATMOS service partner. This ensures that repairs and tests are carried out professionally, original spare parts are used and warranty claims remain unaffected.

Maintenance, repairs, and periodic tests may not be carried out while the product is being used on the patient.

6.1 Periodic tests

Perform a repeat test of the electrical safety according to IEC 62353 at least every 12 months.

In this context, ATMOS recommends conducting an inspection in accordance with the manufacturer's specifications.

6.2 Function check

6.2.1 Visual inspection

- The power cable shows no signs of damage
- The housing is undamaged
- If available: the device is connected correctly and securely to the trolley
- If available: the foot controller is connected correctly
- A new bacterial and viral filter is installed
 - The accessories are complete and without damage

6.2.2 Function test

- The device switches on, the power switch lights up green
- The extraction mode is set correctly (SEMI / AUTO)
- Recognition of foot controller and trolley (only REF 444.0020.0), if available, is shown in the display
- The correct unit of measurement for the vacuum has been set
- SEMI extraction mode:
 - Close the suction hose with your finger
 - An advisory tone sounds at -20 kPa
 - Start extraction
 - The time displayed for vacuum build-up corresponds to requirements
 - The value displayed for the final vacuum corresponds to requirements
 - Vacuum build-up can be accelerated or delayed using the '+' and '-' buttons
 - If available: vacuum build-up can be accelerated or delayed using the foot controller
 - The process is shown correctly on the display (blue colour)
 - An advisory tone sounds when the final value has been reached; the LED of the 'ON' button lights up green
 - The final vacuum can be changed using the '+' and '-' buttons or the foot controller, if available

- After the final vacuum has been reached, the pump switches off and only adjusts when necessary
- The display changes to green
- AUTO extraction mode:
 - Close the suction hose with your finger
 - Extraction starts automatically when -20 kPa has been reached
 - The time displayed for vacuum build-up corresponds to requirements
 - The value displayed for the final vacuum corresponds to requirements
 - Vacuum build-up can be accelerated or delayed using the '+' and '-' buttons
 - If available: vacuum build-up can be accelerated or delayed using the foot controller
 - The process is shown correctly on the display (blue colour)
 - An advisory tone sounds when the final value has been reached; the LED of the 'ON' button lights up green
 - The final vacuum can be changed using the '+' and '-' buttons or the foot controller, if available
 - After the final vacuum has been reached, the pump switches off and only adjusts when necessary
 - The display changes to green
- Stopping extraction
 - Press the 'OFF' button
 - Vacuum decreases in the predefined time
 - The time displayed for vacuum decrease corresponds to requirements
 - The device is in normal suction mode
- Suction mode
 - Switch on the device. The device is in the preset extraction mode
 - Press the 'OFF' button
 - The device switches to normal suction mode
 - The extraction mode symbol disappears from the display
 - The vacuum can be preset using the '+', '-' and 'MAX' buttons
 - Press the 'MAX' button
 - Close the suction hose with your finger
 - The maximum vacuum should reach at least -85 kPa on the display

6.2.3 Monitoring

- Extraction
 - Close the suction hose with your finger
 - Start extraction
 - Open the closed suction hose slightly with your finger
 - A periodic signal sounds and a red LED flashes
 - The pump continues to run
 - The signal clears when the suction hose is closed again
 - After the final vacuum has been reached, open the closed suction hose slightly with your finger
 - A periodic signal sounds and a red LED flashes
 - The pump continues to run
 - The signal clears when the suction hose is closed again
- Monitoring the canister support

- Connect the contact rails on the canister supports with a metal instrument
- The warning message 'Short circuit' appears on the display
- Monitoring the bacterial filter
 - Pull the hose off of the pump connection
 - Close the suction hose with your finger
 - The warning message 'Bacterial filter blocked' shows on the display
- Fill-level monitoring
 - Fill the secretion canister with water up to the level of the fill-level sensor in the canister lid
 - Close the secretion canister with its lid and insert the double hose connector
 - Hang the secretion canister on the device and connect the device and the secretion canister with the hose
 - Switch on the device
 - The warning message 'Secretion canister full' shows on the display

6.3 Sending in the device

1. Remove all consumables and dispose of them properly.
2. Clean and disinfect the product and accessories according to the operating instructions.
3. Enclose any used accessories with the product.
4. Fill in the form QD 434 'Delivery complaint / return shipment' and the respective decontamination certificate.
- ☞ This form is enclosed with each delivery and can be found at www.atmosmed.com.
5. The product must be well padded and packed in suitable packaging.
6. Place the form QD 434 'Delivery complaint / return shipment' and the respective decontamination certificate in an envelope.
7. Affix the envelope to the outside of the package.
8. Send the product to ATMOS or your dealer.

7 Troubleshooting

The product has been subjected to thorough quality control in the factory. However, if a fault should occur, you may be able to resolve it yourself.

Error symptom	Possible cause	Remedy
Device does not switch on (pilot light in the switch does not light up).	Power plug fits poorly.	Check the power plug.
	No power.	Check the power supply on the mains side (building fuse).
Warning message occurs after switching on (filter symbol appears).	Hydrophobic bacterial and viral filter is blocked or not completely dry.	Replace the hydrophobic bacterial and viral filter.
Warning message occurs after switching on (fill-level symbol appears).	Contact element has short-circuited.	Remove metal connection on contact (possibly also on trolley rail!). Also check the connections for trolley fixation on the bottom of the device.
Warning message occurs during suction (fill-level symbol appears).	Secretion canister is full.	Empty the secretion canister.
	Heavy foaming.	Use anti-foaming device.
	When using the trolley, contact strip may be dirty.	Clean the contact strip.
No warning message shows for full secretion canister.	Use of disposable canister system.	The warning message 'Secretion canister full' is deactivated when disposable canister systems are in use. Use reusable secretion canisters.
	Contact fault between the secretion canister and the device.	Check whether the secretion canister and its secretion canister lid have locked into the holder correctly and whether the ATMOS S 351 NATAL has been screwed correctly to the trolley.
Warning message occurs during suction (filter symbol appears).	Hydrophobic DDS bacterial and viral filter is blocked.	Replace the hydrophobic bacterial and viral filter.
	Hose connection to the pump is kinked.	Attach the hose in such a way that it does not kink.
Warning message occurs during suction; device switches off.	Too much foaming; foam bubbles are closing off the contact between the sensor and the double hose connector.	Place anti-foaming device on fill-level sensor (REF 444.0064.0).
No trolley symbol on the display even though the trolley is being used.	The connection to the trolley has been interrupted.	Check the contacts between the trolley and the ATMOS S 351 NATAL.
	Use of the trolley (REF 320.0070.0)	When the trolley is in use, the message 'Connected with trolley' is not possible.

Error symptom	Possible cause	Remedy
Incorrect vacuum unit is showing (mbar / mmHg / kPa).	The wrong vacuum unit was set.	Set the desired vacuum unit as described in chapter '4.6.2 Vacuum unit' on page 22.
The display is too dark / too hard to read.	The brightness of the display is not correct.	Set the desired brightness of the display as described in chapter '4.6.4 Brightness' on page 24.
Spanner/wrench shows on the display.	An equipment error has occurred.	If the symbol disappears, the device was able to correct the error. Nevertheless, have your suction device checked by ATMOS Service.
		Only emergency operation is possible as long as the symbol shows. Call ATMOS Service.
Thermometer shows in the display (ATMOS S 351 NATAL has overheated).	Ventilation slits are blocked.	Check the ventilation slits (bottom of the device); they must not be blocked.
	Ambient temperature is too high.	Use the ATMOS S 351 NATAL only in the specified temperature range. Try using auto standby mode (less heat build-up).
	Fan is defective.	Call ATMOS Service.
Only a low vacuum level can be set with the foot controller.	A low final vacuum level has been set with the buttons.	Set the final vacuum to a higher value (or MAX) using the '+' button to obtain a larger control range for the foot controller.
The device does not recognise the foot controller.	The foot controller was connected after switching on the device.	Connect the foot controller to the device before starting it.

8 Accessories

Accessories	REF
Foot control for ATMOS S 351	444.0478.0
Trolley with standard rail ATMOS S 351	320.0070.0
Secretion canister 1.5 l (PC)	444.0100.0
Secretion canister lid	444.0650.0
Secretion canister lid incl. standard rail holder	444.0015.0
Socket nipple set	444.0640.0
Double socket nipple with overflow electrode	444.0012.0
Stand rail clamp Serres®, ATMOS S 351	444.0484.0
Standard rail support Medi-Vac®	444.0451.0
ATMOS-External Canister 1 l	401.0100.0
Serres®-external canister 1 l	312.0465.0
Medi-Vac®-external canister 1 l	312.0473.0
Safety canister 250 ml (without hydrophobic bacterial and viral filter)	444.0646.0
Safety canister 250 ml (with hydrophobic bacterial and viral filter)	444.0646.1
Hose bracket, for attaching to standard rail	444.0450.0
Hose reducer for double socket nipple	444.0013.0
Power cable 5 m	008.0629.0
Extraction cup, malmstroem, Ø 40 mm	404.0155.0
Extraction cup, malmstroem, Ø 50 mm	404.0156.0
Extraction cup, malmstroem, Ø 60 mm	404.0157.0
ATMOS-Cup, extraction cup silicone, Ø 50 mm	404.0194.0
ATMOS-Cup, extraction cup silicone, Ø 60 mm	404.0193.0
Suction curette, with auxiliary air vent, Ø 6 mm, autoclavable at 134 °C	401.0529.0
Suction curette, with auxiliary air vent, Ø 8 mm, autoclavable at 134 °C	401.0530.0
Suction curette, with auxiliary air vent, Ø 10 mm, autoclavable at 134 °C	401.0531.0
Suction curette, with auxiliary air vent, Ø 12 mm, autoclavable at 134 °C	401.0532.0
Suction curette, with auxiliary air vent, Ø 14 mm, autoclavable at 134 °C	401.0533.0
Suction curette, with auxiliary air vent, for test taking, Ø 3 mm	401.0554.0
Suction curette, with auxiliary air vent, for test taking, Ø 4.0 mm	401.0528.0
Adapter for currettes, Ø 11 mm, autoclavable at 134 °C	401.0553.0

Consumables	REF
DDS bacterial and viral filter, Ø 11 mm	443.0738.0
DDS bacterial and viral filter, Ø 8 mm	444.0628.0
Hydrophobic DDS bacterial and viral filter for DDS secretion canister, 10 pcs.	340.0054.0
Silicone hose for safety canister – secretion canister	443.0046.0
Silicone hose for connecting nipple – bacterial and viral filter	320.0044.0
Silicone hose for safety canister – secretion canister (trolley)	444.0118.0
Silicone hose for bacterial and viral filter – safety canister	999.0128.0
Suction hose, PVC, Ø 8 mm, L = 2.10 m, 50 pcs.	006.0059.0

Consumables	REF
Suction hose, silicone, Ø 6 mm, L = 1.30 m, 1 pc.	000.0013.0
Suction hose, silicone, Ø 6 mm, L = 2 m, 1 pc.	000.0361.0
Suction hose, silicone, Ø 6 mm, 1 m (minimum 5 m)	006.0009.0
Suction hose, silicone, Ø 10 mm, L = 1.30 m, 1 pc.	318.1012.0
Suction hose, silicone, Ø 10 mm, L = 2 m, 1 pc.	000.0243.0
Suction hose, silicone, Ø 10 mm, 1 m (minimum 5 m)	006.0026.0
Extraction hose, green, silicone, Ø 6 mm (minimum 5 m)	006.0010.0
Extraction hose, green, Ø 6 mm, L = 1.5 m	404.0146.0
ATMOS-Suction Bag 1 l with Gelling Agent, 100 pcs.	401.0101.0
ATMOS-Suction Bag 1 l, 100 pcs.	401.0102.0
Serres [®] -suction bag 1 l without gelling agent, 36 pcs.	312.0466.0
Serres [®] -suction bag 1 l, gelling agent, 32 pcs.	312.0467.0
Medi-Vac [®] -suction bag 1 l, 50 pcs.	312.0474.0
Tissue collector 300 ml, disposable	340.0061.0
Suction catheter Unomedical [®] , size: CH 12, length: 53 cm, 100 pcs.	000.0294.0
Suction catheter Unomedical [®] , size: CH 14, length: 53 cm, 100 pcs.	000.0295.0
Suction catheter Unomedical [®] , size: CH 16, length: 53 cm, 100 pcs.	000.0296.0
Fingertip, sterile, not autoclavable, minimum 1 package = 10 pcs.	000.0347.0

9 Disposal

Packaging

1. Please recycle the product packaging.

Secretion and blood

1. Please dispose of secretion, blood and contaminated parts in line with country-specific regulations.

In the Federal Republic of Germany, the requirements of the 'Implementation Aid for Disposal of Waste from Healthcare Institutions' apply, a statement issued by the Federal / State Working Group on Waste.

Secretion canister system

Disposable products may not be reprocessed and may not be reused! Please discard disposable products properly.

The following notes apply only to reusable products.

1. Clean and disinfect the reusable products of the canister system.
2. Recycle the disinfected reusable products.

ATMOS S 351 NATAL

Do not dispose of the product together with household waste.

The product does not contain any hazardous materials.

1. Clean and disinfect the product.
2. Dispose of the product properly and in accordance with country-specific laws and regulations.

Basically, the housing is fully recyclable. However, please observe country-specific laws and regulations.





9.1 Expected service life

When used according to the operating instructions, the device (ATMOS S 351 NATAL) has an expected service life of 8 years. Regular thorough cleaning and disinfection of the suction device and its applied parts as well as operation of the device according to the operating instructions are assumed.

10 Technical data

Input voltage	230 V~ ± 10 %; 50/60 Hz Special voltage: <ul style="list-style-type: none"> • 100 V~ ± 10 %; 50/60 Hz • 115 V~ ± 10 %; 50/60 Hz • 127 V~ ± 10 %; 50/60 Hz
Current consumption	<ul style="list-style-type: none"> • max. 0.5 A (230 V~) • max. 1.3 A (100 V~) • max. 1.3 A (115 V~) • max. 1.3 A (127 V~)
Power consumption	<ul style="list-style-type: none"> • max. 100 VA (230 V~) • max. 130 VA (100 V~) • max. 150 VA (115 V~) • max. 165 VA (127 V~)
Fuses	T 1.0 A/H (for 230 V~) T 2.0 A/H (for 100 V~) T 2.0 A/H (for 115 V~) T 2.0 A/H (for 127 V~)
Air flow rate	36 l/min ± 2 l/min
Max. vacuum at NN	-90 kPa** ** 1 bar ≈ 750.06 mmHg ≈ 1000 hPa / dependent on daily air pressure
Vacuum display	Digital numerical, resolution 10 mbar / 10 mmHg / 1 kPa accuracy ± 2 %
Auxiliary air control	Electronically controlled magnetic valve
Secretion canister	1.5 l / 2.5 l Polycarbonate canisters Supports for using disposable bags: <ul style="list-style-type: none"> • ATMOS (1 l / 2 l / 3 l) • Receptal® (1 l / 1.5 l / 2 l / 3 l) • Serres® (1 l / 2 l / 3 l) • Medi-Vac® (1 l / 1.5 l / 3 l)
Suction tubing	Ø 6 mm, 1.3 m long Ø 10 mm, 2 m long
Power cable	Length: 5 m, with cold-device plug IEC 60320 C14
Interface	<ul style="list-style-type: none"> • For foot regulator • USB interface (only for service)
Power cycle	Continuous operation
Operation mode	Vacuum extraction (SEMI and AUTO) and continuous
Protective conductor resistance	max. 0.1 Ω
Earth leakage current	max. 0.5 mA
Housing leakage current	max. 0.1 mA
Patient leakage current	max. 0.1 mA

Heat output	approx. 135 J/s
Noise level	< 54 dB (A) @ 1 m (ISO 7779)
Environmental conditions: Transport/storage	
Temperature range	-10...+60 °C
Air humidity without condensation	30...95 %
Air pressure	700...1060 hPa
Environmental conditions: Operation	
Temperature range	+5...+40 °C
Air humidity without condensation	30...95 %
Air pressure	700...1060 hPa
Maximum operating altitude	3000 m (NN)
Contamination level	class 2
Overvoltage category	III
Dimensions H x W x D	Without trolley: 30 x 33 x 20 cm With trolley: 88 x 48 x 44 cm
Weight	10.2 kg (without secretion canister and without trolley)
Periodic tests	Periodic tests of electrical safety every 12 months. Recommended: inspection according to manufacturer's specifications.
Protection class (EN 60601-1)	I
Classification of applied parts	Applied parts type B 
Degree of protection	IPX0
CE marking	 0124
Reference number (REF) basic devices	444.0401.0 (230 V) 444.0401.1 (100 V) 444.0401.2 (115 V) 444.0401.3 (127 V)

10.1 Hydrophobic DDS bacterial and viral filter

Protection against bacteria (BFE)	Filtration efficiency: 99.89667 %*
Protection against viruses (VFE)	Filtration efficiency: 99.0 %*
Filter class	H13 (High-Efficiency Particulate Air/Arrestance)*

*External test report (test laboratory)

11 Notes on EMC

☞ Medical electrical devices are subject to special precautions with regard to EMC and must be installed according to the following EMC notes.

Guidance and manufacturer's declaration – ambient conditions

The product is suitable for use in the following environments:

- Home care in any building, outdoor areas and means of transport.
- In professional healthcare facilities such as medical practices, hospitals/clinics, first-aid facilities, and operating theatres/rooms.
It is **not suitable** for use in the vicinity of HF surgical devices and in settings outside of an HF-shielded room of a magnetic resonance imaging system.
- Special environments such as factory or military facilities and medical areas near HF surgical devices, short-wave therapy equipment or within an HF-shielded room of a magnetic resonance imaging system.

The customer or user must ensure that the device is used in a prescribed environment.

Guidance and manufacturer's declaration – key features

☞ Please note the technical data in this manual. The essential features are fully usable even in the presence of electromagnetic disturbances.

Guidance and manufacturer's declaration – electrical components

The product has the following electrical components:

Type	REF	Max. cable length
Power cable with low-heat device plug IEC 60320C14	008.0629.0	5 m

Guidance and manufacturer's declaration – warnings

WARNING

The use of electrical components and accessories other than those specified or provided by the manufacturer may cause increased electromagnetic interference or reduced immunity to electromagnetic interference and result in faulty operation of the device.

WARNING

Portable RF communications equipment (e.g., radios, antenna cables) should be used no closer than 30 cm* to any part of the ATMOS S 351 NATAL, including cables, specified by the manufacturer. Otherwise, this can lead to a reduction in the device's performance.

☞ *The distance may be reduced at higher immunity test levels.

WARNING

Avoid placing the device on top of or next to another device. This could result in faulty operation. If such placement cannot be avoided, the proper functioning of the device must be monitored regularly. If possible, please switch off any nearby devices that are not in use.



MedizinTechnik

ATMOS MedizinTechnik GmbH & Co. KG

Ludwig-Kegel-Str. 16

79853 Lenzkirch/Germany

Phone: +49 7653 689-0

info@atmosmed.com

www.atmosmed.com